

NEUTRONICS INC.

Engineered Solutions for Gas Detection and Analysis

High Purity Instruments

MODEL 7100E

OXYGEN ANALYZER / CONTROLLER – TRACE RANGE

OPERATIONS MANUAL

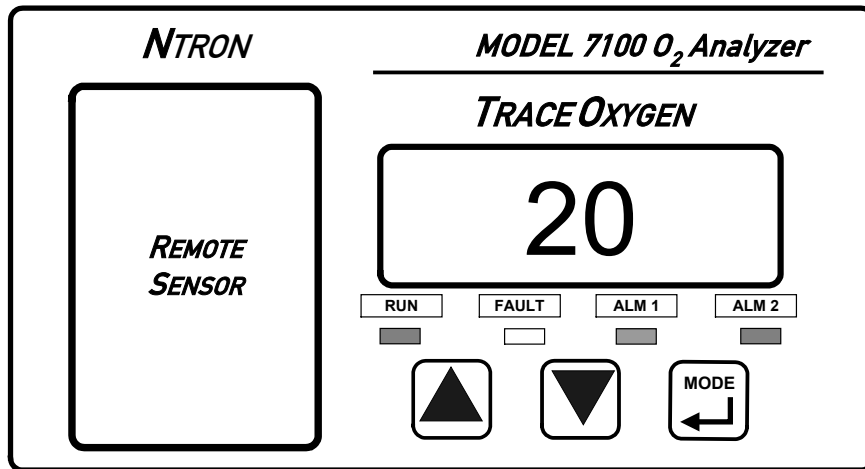

Manual Part Number: C5-06-4900-14-0
Revision Level: A
Revision Date: January 19, 2004



456 Creamery Way, Exton, PA 19341
Phone: 610.524.8800 • Fax: 610.524.8807 • Email: info@neutronicsinc.com
www.neutronicsinc.com

Table of Contents

TABLE OF CONTENTS	III
FOR YOUR SAFETY:	V
WELCOME	VI
CHAPTER 1 – INTRODUCTION AND OVERVIEW	1-1
1.1 GENERAL	1-1
1.2 FEATURES	1-1
1.3 SYSTEM HARDWARE OVERVIEW	1-3
1.3.1 <i>Main Board</i>	1-3
1.3.2 <i>Relay Board</i>	1-3
1.3.3 <i>Power Supply</i>	1-3
1.3.4 <i>Display Board</i>	1-3
1.3.5 <i>Control Panel</i>	1-3
1.3.6 <i>Sensor</i>	1-4
1.3.7 <i>Sensor Flow-Through Head</i>	1-4
1.3.8 <i>Chassis</i>	1-5
1.4 ANALYZER INPUTS AND OUTPUTS	1-7
1.4.1 <i>The Oxygen Sensor Input</i>	1-7
1.4.2 <i>Alarm-1 Relay Output</i>	1-7
1.4.3 <i>Alarm-2 Relay Output</i>	1-7
1.4.4 <i>Fault Relay Output</i>	1-7
1.4.5 <i>Analog Voltage Output</i>	1-7
1.4.6 <i>Analog Current Output</i>	1-8
1.4.7 <i>Range ID Output</i>	1-8
1.4.8 <i>Service Port</i>	1-8
1.5 CONTROL PANEL USER INTERFACE	1-8
1.5.1 <i>The “UP” Pushbutton</i>	1-8
1.5.2 <i>The “DOWN” Pushbutton</i>	1-8
1.5.3 <i>The “MODE” Pushbutton</i>	1-8
1.5.4 <i>7-Segment Alphanumeric Display</i>	1-9
1.5.5 <i>RUN Indicator LED</i>	1-9
1.5.6 <i>Alarm-1 Indicator LED</i>	1-9
1.5.7 <i>Alarm-2 Indicator LED</i>	1-9
1.5.8 <i>Fault Indicator LED</i>	1-9
CHAPTER 2 – SYSTEM INSTALLATION AND START-UP	2-1
2.1 INSTALLING THE ANALYZER	2-1
2.1.1 <i>Step 1 – Locate and Mount the Analyzer unit</i>	2-2
2.1.2 <i>Step 2 –Install the Remote Sensor</i>	2-3
2.1.3 <i>Step 3 –Install the Analyzer</i>	2-5
2.2 STARTING UP AND COMMISSIONING THE SYSTEM	2-10
2.2.1 <i>STEP 1 – Power Up the unit</i>	2-10
2.2.2 <i>STEP 2 – Calibrate the Unit</i>	2-11
2.2.3 <i>STEP 3 –Set Alarm-1 and Alarm-2</i>	2-11

CHAPTER 3 – ANALYZER OPERATION	3-1
3.1 SYSTEM ORGANIZATION.....	3-1
3.2 USER MODES.....	3-1
3.2.1 CALIBRATE Mode & Calibration Procedure.....	3-1
3.2.2 SET/VIEW ALARM-1 Mode	3-4
3.2.3 SET/VIEW ALARM-2 Mode	3-4
3.2.4 VIEW ACTIVE FAULTS Mode	3-4
3.2.5 Return to RUN Mode.....	3-5
3.3 SYSTEM MODES	3-5
3.3.1 Self-Test & Warm-up Mode	3-5
3.3.2 RUN Mode	3-5
3.3.3 ALARM-1 ACTIVE Mode.....	3-6
3.3.4 ALARM-2 ACTIVE Mode.....	3-6
3.3.5 FAULT ACTIVE Mode.....	3-6
CHAPTER 4 – MAINTENANCE AND TROUBLESHOOTING.....	4-1
4.1 SYSTEM SETUP	4-1
4.1.1 System Setup via Control panel Keypad	4-1
4.1.2 System Setup via Service Port	4-3
4.1.3 Change factory settings via Hardware Jumpers	4-12
4.2 ROUTINE PERIODIC MAINTENANCE.....	4-13
4.3 TROUBLESHOOTING	4-14
4.3.1 Fault Codes	4-14
CHAPTER 5 – APPENDICES.....	5-1
5.1 APPENDIX A – SPARE PARTS LIST	5-1
5.2 APPENDIX B - SPECIFICATIONS	5-2
5.3 APPENDIX C – ANALYZER FACTORY CONFIGURATION SETTINGS	5-4
5.4 APPENDIX D – CONTROL PANEL HOT-KEY FUNCTIONS	5-5
5.5 APPENDIX E – RANGE / OUTPUT CHART	5-6
5.6 APPENDIX F – ZERO CALIBRATION RANGE SETTINGS	5-6
5.7 APPENDIX G – MSDS MATERIAL SAFETY DATA SHEET.....	5-7
5.8 APPENDIX H – WARRANTY.....	5-8
INTENDED USE FOR THE MODEL 7100E.....	5-8



For Your Safety:

PLEASE READ THIS MANUAL IN ITS ENTIRETY BEFORE ATTEMPTING INSTALLATION OR OPERATION! Attempting to operate the Model 7100E without fully understanding its features and functions may result in unsafe conditions

- Always use protective eye wear and observe proper safety procedures when working with pressurized gases.
- Always assure the pressure of gas entering the model 7100E is 1-3 psig.
- Always calibrate the model 7100E at an equivalent pressure and flow rate to the measured gas.
- Always allow the model 7100E to cool down before attempting to access the sensor.
- Ensure the model 7100E has been properly calibrated before use.
- Never expose the model 7100E analyzer chassis to water, high humidity or moisture. The analyzer chassis is not watertight.
- Never expose the model 7100E to flame or high temperatures.
- Never expose the model 7100E analyzer to flammable gases or vapors. The unit is not rated Explosion Proof, or Intrinsically Safe.
- Never expose the model 7100E directly to unregulated gas lines, cylinder gas. High gas pressures may cause the oxygen sensor to rupture.
- Ensure the analyzer unit is mounted in an area of free airflow to prevent the chassis from exceeding the operating temperature specifications. Do not mount the analyzer against hot surfaces. Do not block the ventilation louver on the analyzer chassis.

WELCOME

Thank you for purchasing the Model 7100E Analyzer for 1-PPM to 2000-PPM range Oxygen measurement.

The Model 7100E Compact Analyzer is a user friendly, microprocessor controlled Oxygen measuring instrument. It has many features to offer the user, which will be described in this manual. We recommend that all personnel who use the instrument read this manual to become more familiar with its proper operation.

For further detail regarding the maintenance and in-field service of the Model 7100E analyzer, please contact the Neutronics Inc. Customer Service Department. If you have questions or comments, we would like to hear from you.

Neutronics Inc. Customer Service Department

456 Creamery Way

Exton, PA 19341

Tel: (610) 524-8800 ext 118

Toll Free: (800) 378-2287 ext 118 (US only)

Fax: (610) 524-8807

EMAIL: info@neutronicsinc.com

Visit us at www.neutronicsinc.com

Equipment Serial Number: _____

(For faster service, please have this number ready if for any reason you need to contact us about your instrument)

Copyright ©2003 Neutronics Inc.

This work is protected under Title 17 of the US Code and is the sole property of Neutronics Inc. No part of this document may be copied or otherwise reproduced, or stored in any electronic information retrieval system, except as specifically permitted under US copyright law, without the prior written consent of Neutronics Inc.

1

CHAPTER 1 – INTRODUCTION AND OVERVIEW

1.1 General

The model 7100E *Compact Series* analyzer by Neutronics offers an efficient solution in a small package for trace oxygen measurement and control applications. The Model 7100E is a microprocessor-based instrument for measuring zero to 2000-PPM oxygen.

At the heart of the analyzer is the model ZR-400E rapid-response Zirconium Oxide oxygen sensor. This sensor assures reliability and fast response for critical measurements from zero to 2000-PPM. It utilizes a unique solid-state sensor, which offers long life with little periodic maintenance. It is unaffected by dry atmospheres, is undamaged by extremely cold storage temperatures, and has indefinite storage life.

The ZR-400E is remote mounted to allow the sensor to be installed close to a sampling point for the fastest response time possible in process monitoring and control applications. A flow-through mounting head is supplied for use with all Neutronics Inc. process gas sampling systems. Neutronics also provides a wide variety of built-to-application, and custom process sampling systems.

1.2 Features

The *Compact Series* analyzers are designed to be flush mounted to a panel or console. Because of the small size of the Model 7100E analyzer, it can be integrated into a variety of equipment or control panels. The Remote Sensor Module can be mounted close to the sampling point to assure the fastest response possible.

Other Features Include:

- Compact, rapid-response Zirconia oxygen sensor
- Two User-adjustable oxygen Alarms with configurable relay outputs for process control use
- Two Analog Outputs: 4-20 mA AND 0-1, 0-5, or 0-10 VDC
- Auto Ranging or Fixed Range Oxygen Measurement (VDC output provided for auto-range identification)
- Double Redundant Operating System, with automatic repair function
- Bi-directional RS-232 Serial Interface for connection to a PC, terminal, or printer

Model 7100E – Introduction and Overview

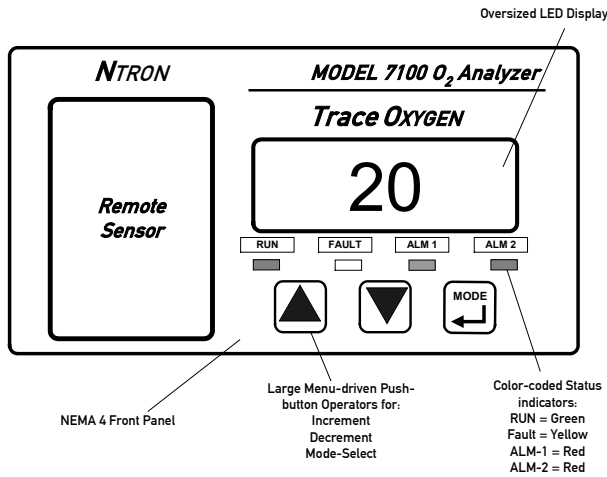

Front view

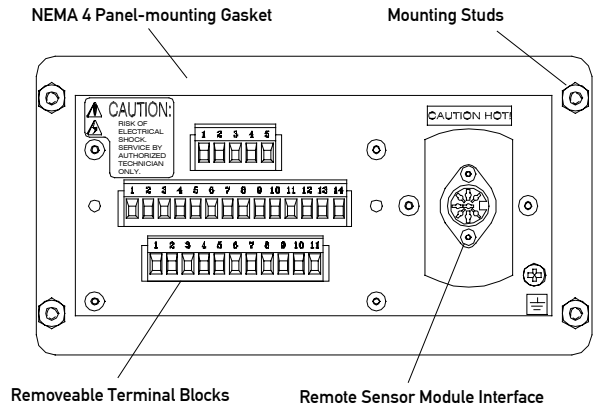

Rear view

Figure 1 – Model 7100E oxygen analyzer front and rear view

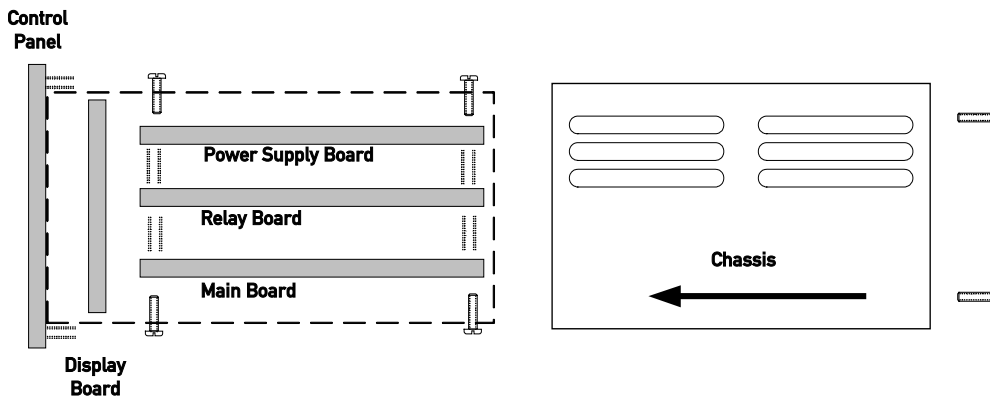

Figure 2 – Basic internal analyzer components

1.3 System Hardware Overview

1.3.1 Main Board

The main board houses the microprocessor, and supporting electronics for controlling the operation of the Model 7100E Analyzer. The main board receives the sensor input, and provides the control and display functions of the analyzer.

1.3.2 Relay Board

The Relay Board houses relay contacts for all of the Alarm and Control features of the 7100E. The relays are mapped discretely to each alarm to provide electrical outputs for reporting, and process control use.

1.3.3 Power Supply

The power supply board is designed to take 110/220 VAC, 50/60 HZ mains power input. The supply is fused directly on the board. Optional 12 VDC and 24 VDC power supplies are available for installations where a DC voltage is required to power the Model 7100E. A 12 VDC battery-backup power input (battery not provided) is also provided to act as an emergency back up in case of mains power failure.

1.3.4 Display Board

The Display board is designed to generate a digital indication of the concentration of oxygen (Appendix E – range / output chart), and fault codes (section 4.3.1). The display is a 7-segment, $\frac{3}{4}$ " alphanumeric LED.

1.3.5 Control Panel

The Control Panel serves as the main user interface. The Control Panel features the keypad (ramp-UP, ramp-DOWN, and MODE keys) and the status LED's. The control panel is designed to be splash and water-resistant. There are #8-32 threaded mounting studs at each of the four corners for flush mounting of the model 7100E to a control or equipment panel. The gasketed panel is suitable for NEMA type 4 / IP20 environments when properly installed.

Model 7100E – Introduction and Overview

1.3.6 Sensor

The Neutronics Inc *ZR-400E mini Zirconia* sensor for measuring percent range oxygen is a cost effective solution for many applications. It is a solid-state device based on a Zirconia solid electrolyte sensor with a low power, on-board heater, and two electrodes. Unlike many solid-state oxygen sensors, the ZR-400E does not require a reference gas for normal operation.

The sensor is mounted directly onto a printed circuit board that supplies bias and heater voltages to the sensor element. A small capillary on the sensor surface controls diffusion of oxygen into the sensor. At operational temperature, oxygen is electrochemically reduced, causing current flow through the solid electrolyte. Oxygen concentration in the sample gas is determined by measuring the current flowing through the sensor's two electrodes.

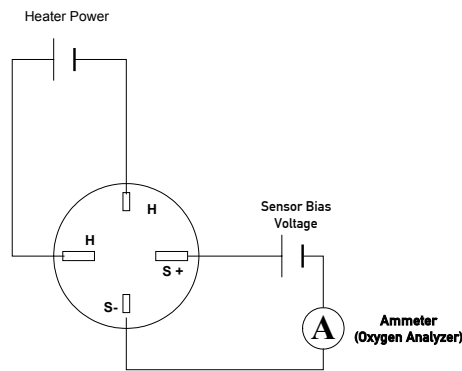

Figure 3 – ZR-400E sensor circuit

The robust design of the ZR-400E sensor assures accurate measurement as well as a quick response characteristic to serve a wide range of oxygen measurement applications. Its expected operating life is 3-5 years under normal operating conditions, and it has an unlimited shelf life. It is not affected by position, and it may be exposed to several G-Force with no ill effect on performance.

1.3.7 Sensor Flow-Through Head

The sensor mounting-base allows the model ZR-400E sensor to be used for process monitoring. It serves as both the receptacle for the sensor and the delivery system for a gas sample from a process vessel or stream. It includes a sample inlet, a flow-through chamber a sample exhaust, and a screw-in receptacle for the oxygen sensor.

1.3.7.1 Sample Gas Inlet

Gas must be directed from the measured process to the sample inlet port via positive pressure from the source, or an external pump. The model ZR-400E sensor and flow-through head combination can be installed in any Neutronics Inc. Process Sampling System.

1.3.7.2 Sample Gas Exhaust

A sample gas exhaust port is provided for installation with a process oxygen sampling system. Gas must be directed from the sample exhaust port to a suitable vent source that does not apply significant backpressure on the sampling system. The unit can be installed in-line with any Neutronics Inc. Process Sampling System.

**Figure 4 –
Sensor flow-
through head**

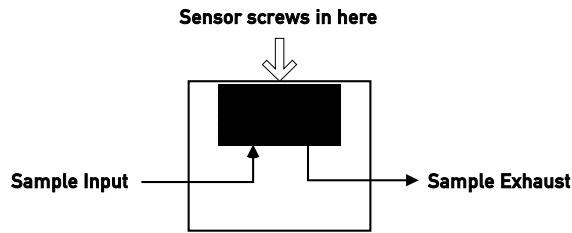

1.3.8 Chassis

The chassis is manufactured of specially coated steel. It is designed to provide a general level of protection against mechanical damage from the local environment. It is also an important component of the electrostatic discharge (ESD) shielding design. Since the Model 7100E is a flush mounted system, the portion of the instrument housed in the chassis will be located behind the control panel or embedded within the customer equipment enclosure. The enclosure is general purpose and is not watertight.

**Figure 5 –
Analyzer chassis**

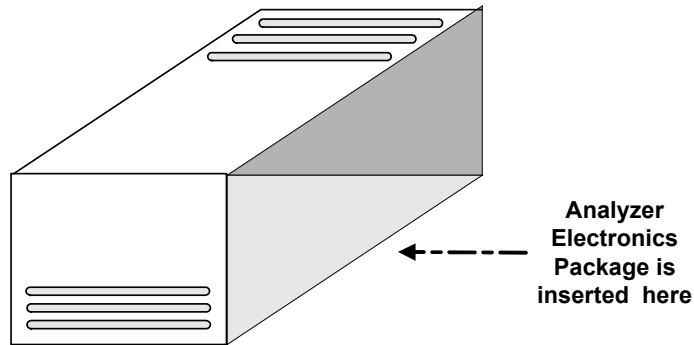

Model 7100E – Introduction and Overview

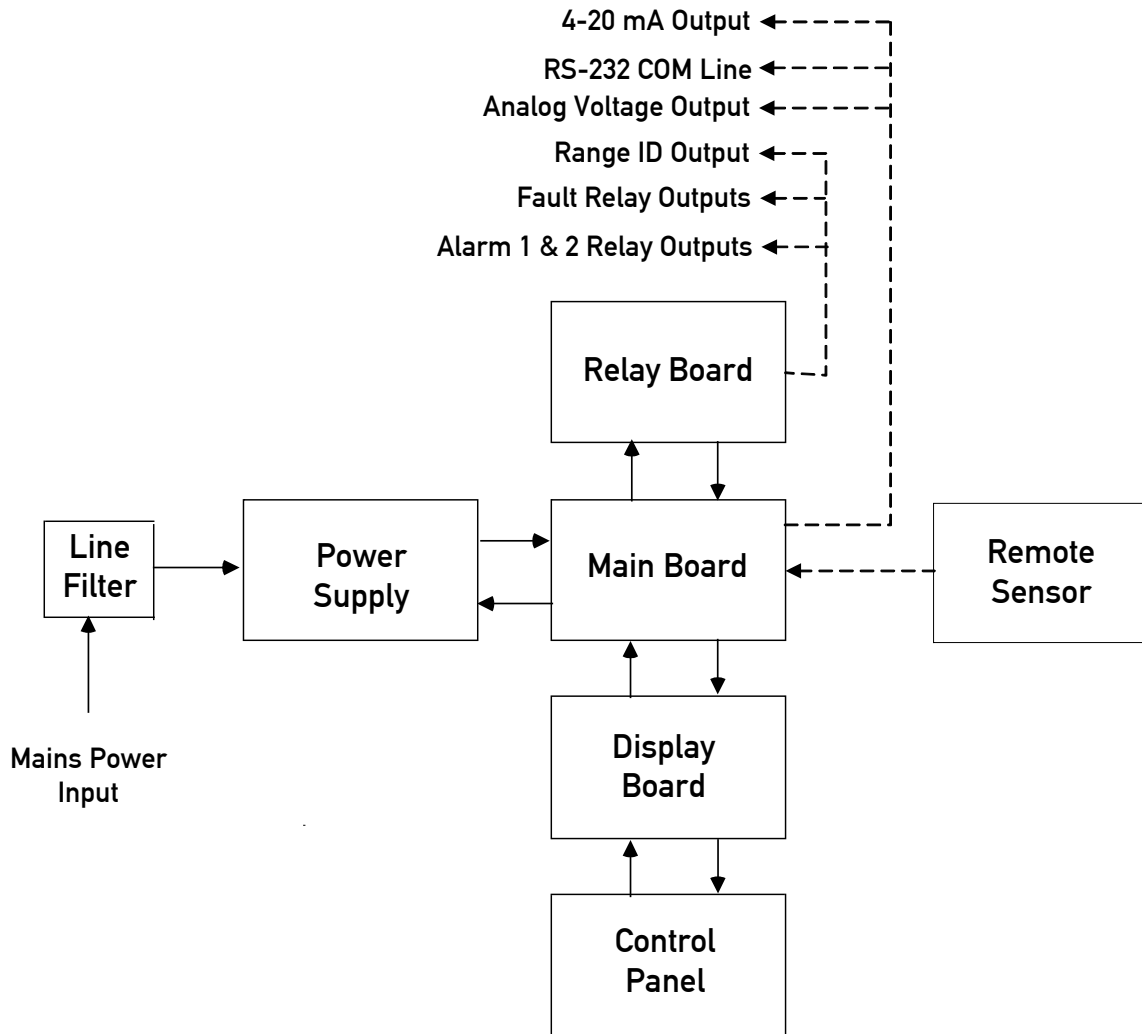

Figure 6 – Analyzer system configuration

1.4 Analyzer Inputs and Outputs

1.4.1 The Oxygen Sensor Input

The oxygen sensor electrical input to the model 7100E is used to indicate the oxygen concentration measured by the model ZR400E oxygen sensor. It is proportional to the oxygen present in the measured gas at the sensor membrane. The oxygen sensor input is a female 7-pin DIN connector to mate with the supplied sensor interface cable connector.

1.4.2 Alarm-1 Relay Output

The Alarm-1 relay is mapped to the Alarm-1 setpoint, and is provided for process control use. The user may set the oxygen level at which Alarm-1 activates (section 3.2.2). Alarm-1 may be configured as ascending (highest oxygen level allowable) or descending (lowest oxygen level allowable) action. The relay output may be configured for fail-safe (relay coil de-energized in alarm state) or non fail-safe (relay coil energized in alarm state) action. Factory default settings are ascending, and fail-safe (Appendix C, Factory Configuration). The Alarm-1 relay contacts are form C (DPDT), voltage-free.

1.4.3 Alarm-2 Relay Output

The Alarm-2 relay is mapped to the Alarm-2 setpoint, and is provided for process control use. The user may set the oxygen level at which Alarm-2 activates (section 3.2.3). Alarm-2 may be configured as ascending (highest oxygen level allowable) or descending (lowest oxygen level allowable) action. The relay output may be configured for fail-safe (relay coil de-energized in alarm state) or non fail-safe (relay coil energized in alarm state) action. Factory default settings are ascending, and fail-safe (Appendix C, Factory Configuration). The Alarm-2 relay contacts are form C (DPDT), voltage-free.

1.4.4 Fault Relay Output

The Fault relay output is used to indicate that there is at least one system fault active on the Model 7100E analyzer (section 4.3.1 – fault codes and definitions). The relay output action is non fail-safe, and is not configurable. The Fault relay contacts are Form B (SPST), voltage-free.

1.4.5 Analog Voltage Output

The Analog Voltage output is a dynamic potential used to indicate to a remote device the displayed oxygen concentration during normal analyzer operation and system maintenance. The Analog voltage output follows the oxygen readout displayed on the 7-segment LED display during all system and user modes except for user setup. For a complete listing of available output levels by analyzer range, refer to Appendix E – range / output chart.

The Analog voltage range can be adjusted by the user (section 4.1 – system setup). Available settings are 0-VDC for minimum-scale-deflection, to 1, 5 or 10-VDC full-scale. The factory default setting is 0-1 VDC (Appendix C, Factory Configuration). The Analog voltage output is scaled according to the analyzer's selected range, and must be used in conjunction with the Range ID voltage when the Analyzer is configured for auto-ranging (section 1.4.8).

Model 7100E – Introduction and Overview

1.4.6 Analog Current Output

The Analog Current output is a dynamic current flow used to indicate to a remote device the displayed oxygen concentration during normal analyzer operation and system maintenance. The Analog Current output follows the oxygen readout displayed on the 7-segment LED display during all system and user modes except for user setup. For a complete listing of output levels by analyzer range, refer to Appendix E – range / output chart.

The minimum scale deflection may be set to either 0 mA or 4 mA. Full-scale is fixed at 20 mA. The Analog current output is scaled according to the analyzer's selected range, and must be used in conjunction with the Range ID voltage when the Analyzer is configured for auto-ranging (section 1.4.8).

1.4.7 Range ID Output

The model 7100E can be configured by the user to automatically switch its measurement range, based on the concentration of oxygen measured while in-service, to provide the most accurate, and highest resolution outputs at all times. For a complete listing of analyzer ranges, refer to Appendix E – range / output chart.

Remote auxiliary devices designed to interpret the model 7100E Analog outputs over multiple output range scales require an indication of the analyzer's selected range at all times for accurate scaling. The model 7100E features a 0-10 VDC Auto-Range Identification output. The range ID output is used in conjunction with the Analog voltage and Analog current outputs when auto-ranging is used. It provides an indication of the Analog outputs' selected full-scale. There are four range ID voltage levels used in the 7100E to correspond with its four output ranges (Appendix E – range / output chart).

1.4.8 Service Port

The Service port provides a user-friendly means of digital communications with the Model 7100E Analyzer. Through this port, the unit may be configured, calibrated, and queried for most functions. The RS-232 port may also be programmed to send out information on a timed basis for users who prefer to use Digital instead of Analog interfacing with the analyzer. In addition, the service port may be used with a PC based computer (such as a portable notebook computer) over a standard bi-directional RS-232 serial interface.

1.5 Control panel User Interface

1.5.1 The “UP” Pushbutton

The “UP” pushbutton can be used to program the model 7100E via the control panel. This momentary push-button soft key is used to enter incremental information. Its function is menu-driven.

1.5.2 The “DOWN” Pushbutton

The “DOWN” pushbutton can be used to program the model 7100E via the control panel. This momentary push-button soft key is used to enter decremental information. Its function is menu-driven.

1.5.3 The “MODE” Pushbutton

The “MODE” pushbutton can be used to program the model 7100E via the control panel. This momentary push-button soft key is used to navigate the operational modes available through the control panel. Its function is menu-driven.

1.5.4 7-Segment Alphanumeric Display

The 7-Segment alphanumeric display feeds back information from the model 7100E to the user via the control panel. The primary purpose of the 7-Segment display is to show the oxygen concentration readout. It is also used for feedback of operational status, fault codes, and other information necessary to perform system setup and maintenance.

1.5.5 RUN Indicator LED

The purpose of the RUN Indicator LED is to inform the user via the control panel that the model 7100E is measuring the concentration of the sample gas and updating the display and outputs accordingly, and has not detected any alarm, or fault conditions.

1.5.6 Alarm-1 Indicator LED

The purpose of the Alarm-1 Indicator LED is to inform the user via the control panel that the measured oxygen concentration has exceeded the alarm-1 threshold; alarm-1 and its associated relay are in active mode.

1.5.7 Alarm-2 Indicator LED

The purpose of the Alarm-2 Indicator LED is to inform the user via the control panel that the measured oxygen concentration has exceeded the alarm-2 threshold; alarm-2 and its associated relay are in active mode.

1.5.8 Fault Indicator LED

The purpose if the Fault Indicator LED is to inform the user via the control panel that at least one system fault is active. Note that when the fault Indicator LED is active, the fault relay will also be active.

2 CHAPTER 2 – SYSTEM INSTALLATION AND START-UP

2.1 Installing the Analyzer

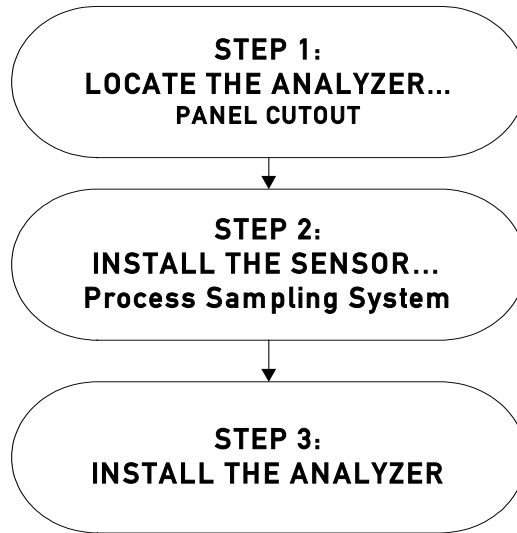

Figure 7 – Installation outline

System Installation and Startup

2.1.1 Step 1 – Locate and Mount the Analyzer unit

The model 7100E is designed to be mounted flush to the surface of a stationary equipment control panel. Select a suitable location for the analyzer unit where the digital display and status LED's will be easy to read, and the interface buttons on the display panel will be easy to access.

Cut/drill the mounting panel to the specifications in figure-8. Clearance holes for the #8-32 threaded mounting studs do not need to be tapped. Hex nuts are included for securing the unit to a panel. Trim all burrs or sharp edges in the cutout or mounting-holes, which would interfere with or damage the gasket on the analyzer control panel.

Slide the analyzer unit into the cutout, rear-chassis first, and seat the control panel gasket on the mounting surface. The gasket on the analyzer control panel ensures a watertight seal around the control panel cutout. Secure the threaded mounting studs with the supplied hex-nuts, and internal-tooth lock-washers. The analyzer control panel is suitable for NEMA Type 4, IP20 environments when properly installed. The rear electronics chassis is suitable for NEMA Type 1, IP 20 environments.

The analyzer should not be exposed to water, adverse temperature, or shock. Ensure the analyzer unit is mounted in an area of free airflow to prevent the chassis from exceeding the operating temperature specifications. Do not mount the analyzer or sensor against hot surfaces. Do not block the ventilation louver on the analyzer chassis.

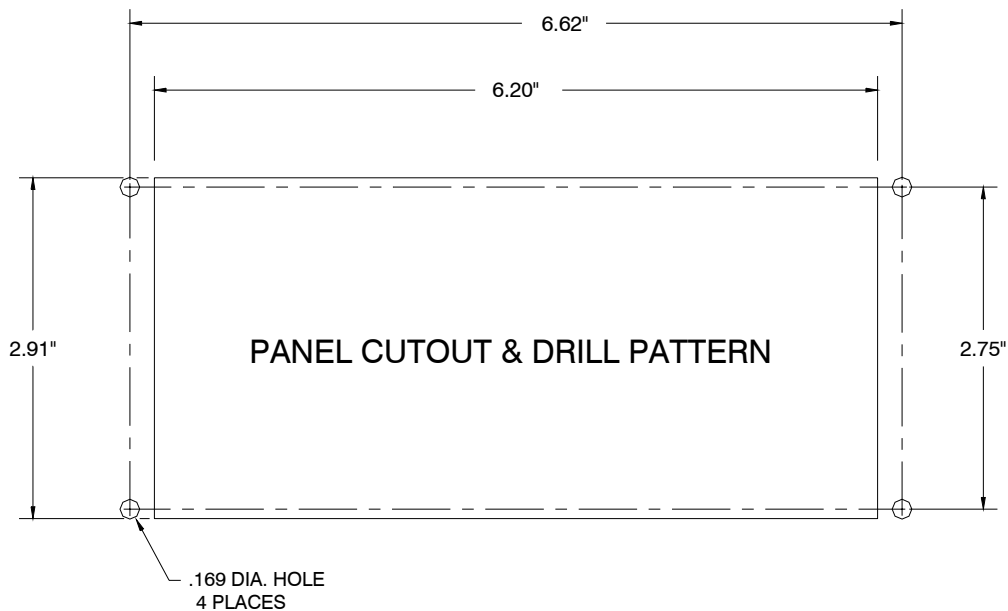

Figure 8 – Analyzer cutout

2.1.2 Step 2 –Install the Remote Sensor

The model 7100E is supplied with a model ZR-400E oxygen sensor, and sensor flow-through head for connection to a sampled process gas stream, and a sensor interface cable. The model 7100E can also be supplied with a Neutronics Inc. process Sampling system, built-to-application. For detailed instructions on remote sensor installation with a Neutronics Inc. Process Sampling System, please refer to the equipment manual.

2.1.2.1 Flow-through Head

Surface-mount the flow through head horizontally (as shown in figure 8) or vertically on a stationary panel. The sensor flow-through head is 1.25" diameter stainless steel, and is machined to accommodate two # 6-32 machine-type mounting screws (1-inch on center). Be careful not to over tighten the mounting screws. Allow sufficient space to screw the model ZR-400E oxygen sensor into the top threaded port of the flow through head, and for the sample lines and sample inlet and exhaust fittings.

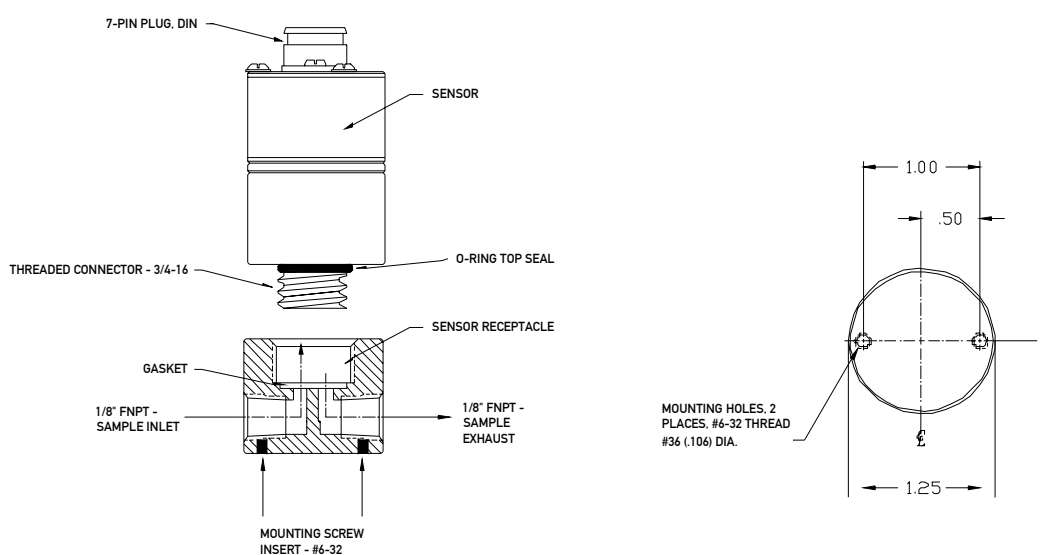

Figure 9 – Sensor installation detail

2.1.2.2 Sample Inlet Port

Pneumatic connection to the measured process for sample extraction is made at either of the two interchangeable 1/8" FNPT fitting around the side of the flow-through head. For connecting the flow-through head to the measured process, use 1/8" or 1/4" rigid tubing, and 1/8" MNPT fittings of a material compatible with process gas composition. Ensure that no grease, particulate, or solvent is present in the tubing during installation. Use thread-tape to seal connections, and prevent gauling. Fix all sample tubing and connectors.

A fixed calibration port may be implemented in the process sampling line by installing a 1/8" or 1/4" 3-way manual ball valve into the sampling line as in figure-9. Use 1/8" or 1/4" rigid tubing and 1/8" MNPT fittings of a material compatible with process gas composition. Ensure that no grease, particulate, or solvent is present in the tubing during installation. Use thread-tape to seal connections, and prevent gauling. Fix all sample tubing and connectors.

System Installation and Startup

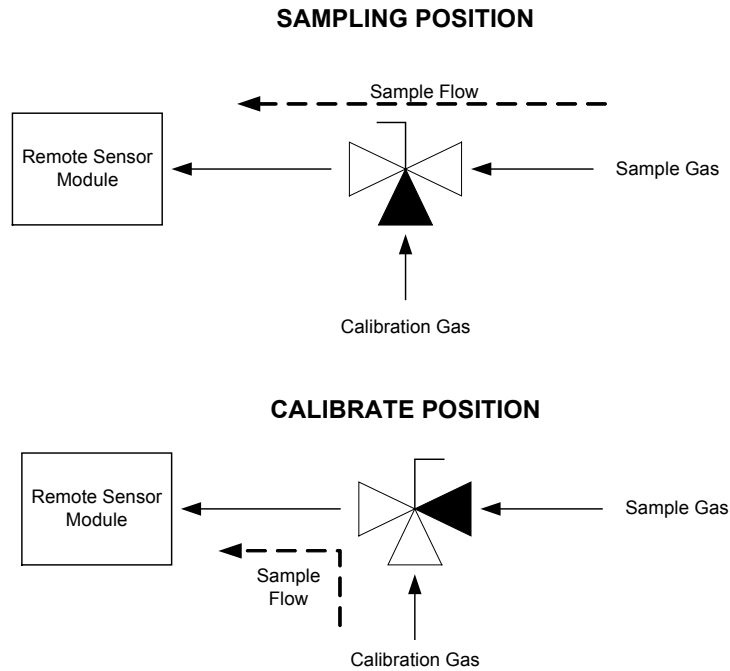

Figure 10 – Calibration gas fixture configuration

2.1.2.3 Sample Exhaust Port

Pneumatic connection to the measured process for sample extraction is made at either of the two interchangeable 1/8" FNPT fitting around the side of the flow-through head, but opposite the installed sample inlet port (section 2.1.2.2). For connecting the sample exhaust to vent, use 1/8" or 1/4" rigid tubing and 1/8" MNPT fittings of a material compatible with process gas composition. Select a vent location that is known to be at atmospheric pressure at all times. Use a minimum 2-meters of tubing to prevent back-flow of vent gas to the sensor. Ensure that no grease, particulate, or solvent is present in the tubing during installation. Use thread-tape to seal connections, and prevent gauling. Fix all sample tubing and connectors.

2.1.2.4 Sensor

The ZR-400E sensor pneumatic connection to the process gas stream is made at the 3/4-16 threaded flow-through head connection with a supplied top seal o-ring and receptacle gasket. Electrical connection to the model 7100E is made at the female 7-pin DIN connector with a screw-on capture ring.

Connect the sensor to the flow-through head. Verify the supplied o-ring is in place at the base of the sensor, over the 3/4-16 threaded connector. Do not lubricate the o-ring. Verify the supplied gasket is seated in the bottom of the flow-through head sensor receptacle. Screw the sensor into the flow-through head sensor receptacle, and hand-tighten. Do not over-tighten. The o-ring and gasket should be slightly compressed. Match the sensor threaded flow-through head connection against the mating receptacle in the sensor flow-through head.

2.1.3 Step 3 –Install the Analyzer



DANGER: Electrical connections on the rear of the Model 7100E Oxygen analyzer may have hazardous voltages present once power has been applied to the unit. High voltages may remain present for a short time even after power has been disconnected from the analyzer. Take care in observing standard electrical practices when making electrical connections to the Model 7100E Oxygen analyzer.

DANGER: The model 7100E analyzer is not rated intrinsically safe or explosion proof. Be certain that no flammable gases are present in the area where the Model 7100E analyzer will be installed.

CAUTION: The model 7100E housing is not rated waterproof. Do not mount the analyzer or the sensor in an area where it may contact water or other liquid elements.

WARNING: Be certain that all power is OFF to the analyzer and associated wiring (cables) before attempting installation. **DO NOT WORK WITH LIVE WIRES!** Do not leave any exposed wire at the terminal blocks. Before applying power, ensure terminal blocks are fully inserted into the mating connector at the analyzer.

System Installation and Startup

A label depicting the terminal block arrangement is affixed to the top of the chassis for easy reference during installation and maintenance (VAC configuration shown below). The terminal blocks feature screwed terminals. The terminal blocks are also removable for ease of wiring or removal of the analyzer module.

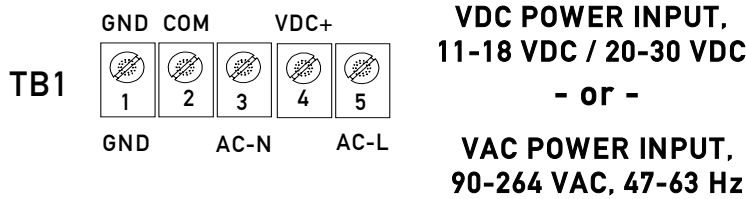
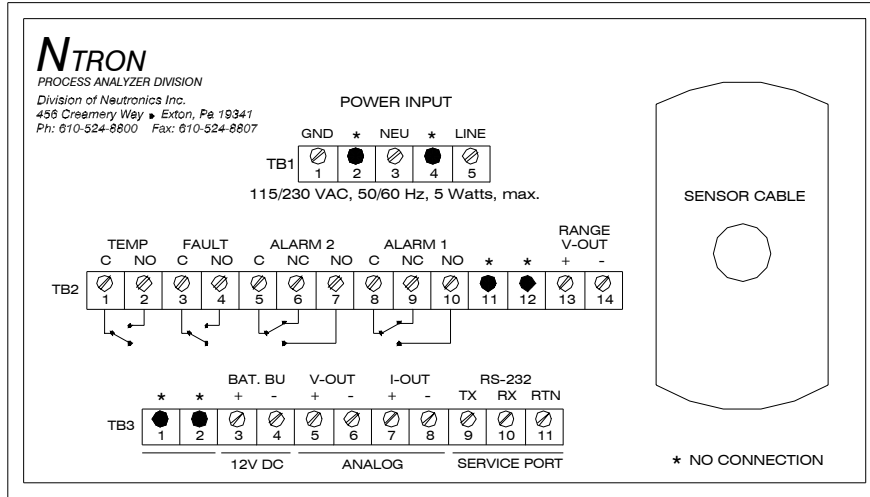

* Refer to Appendix C - Factory Configuration for the correct DC voltage to use with your unit

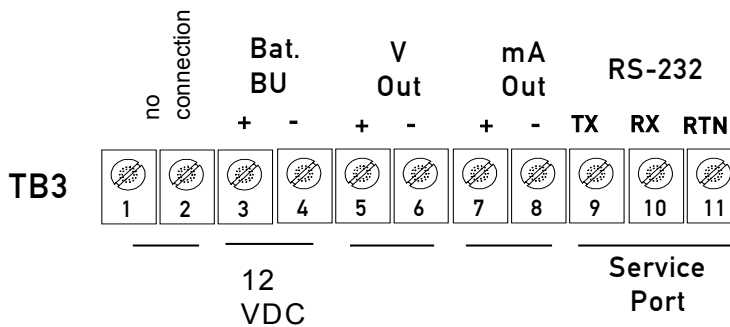
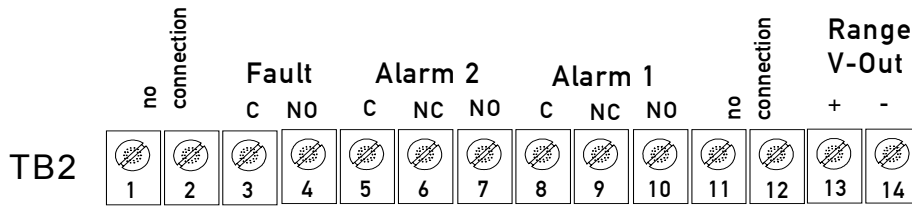

NO = Normally Open
NC = Normally Closed
C = Common

Figure 11 – Analyzer chassis electrical connections

2.1.3.1 Alarm-1 Relay Output

Connections from the Alarm-1 relay contacts to the user's process control equipment are made at terminal block TB2 on the rear of the analyzer chassis. The Oxygen Alarm relay contacts are voltage-free Form C relay contacts, SPDT, 5A @ 250 VAC, 5A @ 30 VDC. Be certain to match the terminal pins against the terminal ID label on the top of the analyzer chassis.

2.1.3.2 Alarm-2 Relay Output

Connections from the Alarm-2 relay contacts to the user's process control equipment are made at terminal block TB2 on the rear of the analyzer chassis. The Oxygen Alarm relay contacts are voltage-free Form C relay contacts, SPDT, 5A @ 250 VAC, 5A @ 30 VDC. Be certain to match the terminal pins against the terminal ID label on the top of the analyzer chassis.

2.1.3.3 Fault Relay Output

Connections from the Fault relay contacts to the user's process control equipment are made at terminal block TB2 on the rear of the analyzer chassis. The Fault relay contacts are voltage-free Form B relay contacts, SPST, 5A @ 250 VAC, 5A @ 30 VDC. Be certain to match the terminal pins against the terminal ID label on the top of the analyzer chassis.

2.1.3.4 Range ID Output

Connections from the Range ID output to the user's auxiliary equipment are made at terminal block TB2 on the rear of the analyzer chassis. Be certain to match the terminal pins against the terminal ID label on the top of the analyzer chassis.

Use 20-AWG, 2-conductor, stranded-wire, twisted pairs for the connections. It is not necessary to use shielded cable for the Range ID output, with or without electrical barriers. If shielded cable is used, it should be drained to dc ground at the auxiliary equipment.

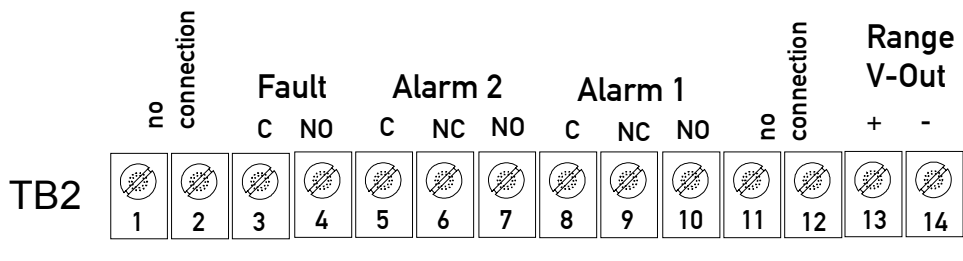

System Installation and Startup

2.1.3.5 Analog Voltage Output

Connections from the Analog Voltage output to the user's auxiliary equipment are made at terminal block TB3 on the rear of the analyzer chassis. Be certain to match the terminal pins against the terminal ID label on the top of the analyzer chassis.

Use 20-AWG, 2-conductor, stranded-wire, twisted pairs for the connections. It is not necessary to use shielded cable for the Analog Voltage output, with or without electrical barriers. If shielded cable is used, it should be drained to dc ground at the auxiliary equipment.

2.1.3.6 Analog Current Output

Connections from the Analog Current output to the user's auxiliary equipment are made at terminal block TB3 on the rear of the analyzer chassis. The Analog current output is a negative ground, non-isolated 0-20mA, or 4-20 mA current loop. 12 VDC Power is supplied by the Model 7100E analyzer. Maximum electrical loading is 250 Ohms. Be certain to match the terminal pins against the terminal ID label on the top of the analyzer chassis.

Use 20-AWG, 2-conductor, stranded-wire, twisted pairs for the connections. It is not necessary to use shielded cable for the Analog Current output, with or without electrical barriers. If shielded cable is used, it should be drained to dc ground at the auxiliary equipment.

2.1.3.7 Battery Backup

12-volt DC Battery Backup terminals are provided at terminal block TB3 on the rear of the analyzer chassis. These terminals may be connected to a fixed 12 VDC power source to act as a back up in case mains power has been lost. The circuit will detect loss of the mains power and the VDC battery backup will maintain power to the system.

Connection to the battery backup is not required for normal operation of the analyzer. Be certain to match the terminal pins against the terminal ID label on the top of the analyzer chassis.

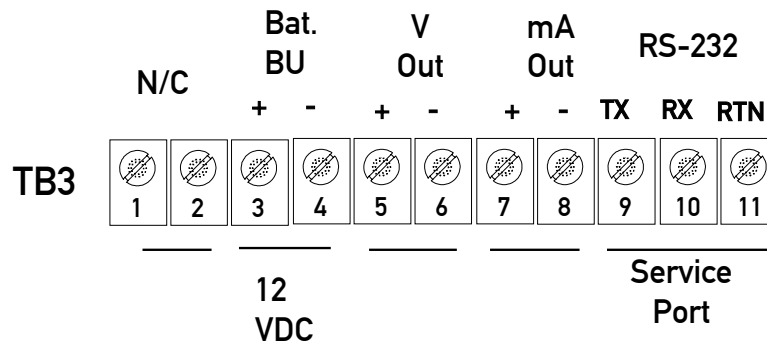

2.1.3.8 RS-232 Service Port

Connections from the Range ID output to the user’s auxiliary equipment are made at terminal block TB3 on the rear of the analyzer chassis. Be certain to match the terminal pins against the terminal ID label on the top of the analyzer chassis.

For interfacing with any standard PC computer via serial port, use 20-AWG, 3-conductor, shielded, stranded-wire, jacketed cable, terminated on one end with a female DB9 connector. The shielding should be drained to dc ground at the computer.

SIGNAL DESIGNATION AT ANALYZER	ANALYZER TB2 CONNECTION	SIGNAL DESIGNATION AT COMPUTER	COMPUTER DB9 SERIAL PORT CONNECTION
RX	Pin 9	TX	Pin 2
TX	Pin 10	RX	Pin 3
RTN	Pin 11	RTN	Pin 5

2.1.3.9 Mains Power

Connections for Mains Power input are made at terminal block TB1 on the rear of the analyzer chassis. Be certain to match the terminal pins against the terminal ID label on the top of the analyzer chassis.

For VAC versions, use minimum 16-AWG, 3-conductor, stranded-wire, for the connections. Supply single-phase 110/220 VAC, 50/60 HZ to the unit. For VDC versions, use 18-AWG, 3-conductor, stranded-wire, for the connections. Supply 12 or 24 VDC to the unit. Refer to Appendix C – Factory Configuration for the correct DC voltage to use with your unit. Refer to Appendix B for detailed mains power specifications.

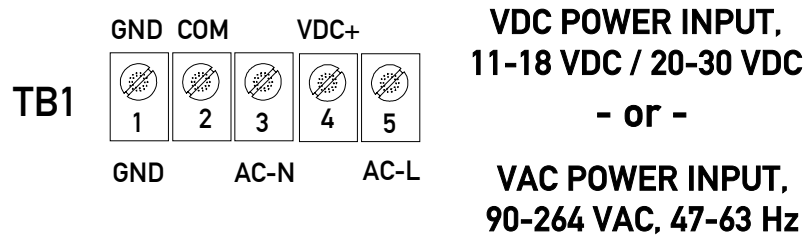

* Refer to Appendix C - Factory Configuration for the correct DC voltage to use with your unit

2.2 Starting up and Commissioning the System

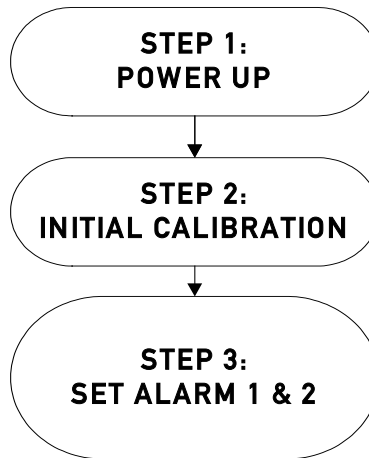

Figure 12 – Start-up outline

The Model 7100E is shipped ready to use, right from the carton. Factory default configuration settings are listed in Appendix C for your information. Those settings will be suitable for most applications. Review the factory default configuration settings before commissioning your system. If you wish to change any of the factory default settings, refer to sections 4.1.1 and 4.1.2.

POWER UP CHECK LIST

Have you:

- Mounted the analyzer and sensor in areas where there are no flammable vapors?
- Mounted the system away from exposure to rain, dripping water, or hose down?
- Correctly installed all of the wiring?
- Connected the sensor interface cable at both the sensor and analyzer?
- Ensured gas tight plumbing at the sensor flow-through head?
- Regulated the sample pressure as instructed in section 2.1.2.4?
- Read this manual in its entirety?

2.2.1 STEP 1 – Power Up the unit

When the model 7100E is powered-up, it will go through a 5-second self-test. The 7-segment alphanumeric display will show “8.8.8.8.”, then XXXX (software build). The Run, Alarm-1, Alarm-2 and Fault LED indicators will go through a display test sequence (Lamp Test). The unit will then begin a 60-second warm-up period for the heated Zirconium Oxide oxygen sensor. The 7-segment alphanumeric display will show alternately XX.X (the timer count-down in seconds), and “nr”.

When the warm-up period is complete, the model 7100E will check the sensor signal, update the display and status LED’s, and enter into the appropriate system mode according to programmed parameters (Appendix C – system configuration). Once the analyzer reading has stabilized, the user may apply a PPM test gas to the sensor to check the system. Allow the new reading to stabilize. It should take about 5-minutes for the gas to sweep out the sample lines, depending on the length.

2.2.2 STEP 2 – Calibrate the Unit

All units are calibrated at the Neutronics factory before shipping. However, it is recommended that the model 7100E be calibrated at commissioning, under ambient and process conditions similar to those encountered while in-service. Refer to section 3.2.1 for detailed analyzer calibration instructions.

Helpful hint The model 7100E is configured-to-order, as specified by the user per the application. If the application has changed, some adjustments in the system configuration may be necessary to optimize the model 7100E performance for the application. After reviewing the calibration instructions, review Appendix C – Factory Configuration Settings. Verify that the current settings are suitable for the application. Refer to Appendices E and F for all valid range and output settings available on the model 7100E. If any changes are necessary, they can be performed via the control panel (section 4.1.1) or the service port (section 4.1.2).

2.2.3 STEP 3 –Set Alarm-1 and Alarm-2

After the unit has been calibrated on known gas sources, set the alarm thresholds according to process control requirements. Refer to Appendix C for factory settings.

2.2.3.1 Set Alarm-1

For process control applications, alarm-1 is used normally as the “primary” oxygen-level alarm, and is set to the highest or lowest level of oxygen allowable in your process, according to the application. Refer to section 3.2.2 for information about changing the alarm-1 level.

2.2.3.2 Set Alarm-2

For process control applications, alarm-2 is used normally as the “secondary”, or “warning” oxygen-level alarm, and is set just below to the highest, or just above the lowest level of oxygen allowable in your process, according to the application. Refer to section 3.2.3 for information about changing the alarm-2 level.

The Model 7100E should now be ready for commissioning. Neutronics Inc. offers commissioning, and Factory Acceptance Testing services by our qualified technicians. You may contact the Neutronics factory toll-free at (800) 278-2287 in the continental United States. Elsewhere, call (610) 524-8800 and ask an Ntron Division Service Technician to schedule a service call.

3

CHAPTER 3 – ANALYZER OPERATION

3.1 System Organization

The Model 7100E has two types of operational modes – User-type, and System-type. User modes are initiated and controlled by the user, and are used to setup and maintain the analyzer. The User modes are: Calibration, Set/View Alarm-1, Set/View Alarm-2, View Active Faults, and Setup. Operating modes are accessed automatically by the Model 7100E during normal operation, according to its programming, and its configuration parameters. The Operating modes are: Self-Test & Warm-up, Run, Alarm-1 Active, Alarm-2 Active, and Fault Active.

3.2 USER Modes

At any time, the user can initiate any of the user modes either from the control panel or through the service port. Control panel access of the Calibration, Set/View Alarm-1, Set/View Alarm-2 and View Active Faults modes will be covered in this chapter. System setup mode and user access via the service port will be covered in section 4.1.

The user modes Calibration, Set/View Alarm-1, Set/View Alarm-2 and View Active Faults are accessed serially via the control panel, in the aforementioned order by repeatedly pressing and releasing the “MODE” key. When a user mode is accessed via the control panel, the model 7100E aborts any system mode active, and holds the state of Alarm-1, Alarm-2, Fault, and Heater OK relay outputs until the user returns the unit to Run mode.

3.2.1 CALIBRATE Mode & Calibration Procedure

Calibration mode allows the oxygen sensor and analyzer to be aligned to gases of known oxygen concentration for the most accurate on-line readings. For best accuracy, the model 7100 requires calibration at system commissioning, and after the oxygen sensor has been replaced (the oxygen sensor can only be replaced at the Neutronics factory). The model 7100 uses a non-depleting solid-state oxygen sensor. During the normal service life of the sensor (3-4 years), no additional calibration is required.

3.2.1.1 CALIBRATION – Introduction

For best application-driven accuracy, the model 7100 is capable of a flexible two-point calibration, customized by the user to fit the application. There is no need for a fixed “zero” calibration, and calibration gases may be selected almost anywhere within the analyzer’s configured range.

The user may select “high” and “low” calibration gases that profile the in-service oxygen measurement range. When gases are selected properly, the analyzer recognizes them as high and low calibration gases automatically during the calibration sequence, and applies any user-entered correction factors accordingly.

To calibrate the system (section 3.2.1.3), the user just applies a gas to the sensor, adjusts the reading on the analyzer control panel to match the oxygen concentration in the gas, and repeats the same simple procedure using another gas. The analyzer does the rest. When the procedure is complete, the model 7100 is aligned to the user’s specific oxygen measurement needs.

Analyzer Operation

3.2.1.2 CALIBRATION Step-1: Select calibration gases

To calibrate the model 7100, the user will select two gases with oxygen concentrations that profile the expected average upper and lower extremes of the in-service oxygen measurement range. This manual will refer to those gases as the “high” and “low” calibration gases respectively.

To set up automatic recognition of selected calibration gases, a few guidelines must be followed. The model 7100 uses a field-adjustable reference range setting called *Assume Low End Calibration* in the analyzer setup menu (sections 4.1.1.6 and 4.1.2.16) to determine which gas is the LOW calibration gas, and which one is the HIGH calibration gas.

Proper system operation requires that the user select one gas within the *Assume Low End Calibration* range, and another gas that is above that range. During the calibration procedure, the model 7100 will assume the former is the intended LOW calibration gas, and the latter is the intended HIGH calibration gas.

The following calibration gas sources can be used to calibrate the model 7100:

- Certified Standard grade bottled calibration gas – 10 PPM to 1,000 PPM O₂

3.2.1.2.1 Selecting LOW Calibration Gas

The LOW calibration gas must have an oxygen concentration ≥ 10 PPM, and within the limits of the *Assume Low End Calibration* range in the analyzer setup menu. Refer to Appendix C for the factory-configured *Assume Low End Calibration* range setting.

The *Assume Low-End Calibration* range is user-adjustable to provide best on-line measurement range profiling. Appendix E shows all settings available in the user setup menu, and an indication of those settings applicable to the model 7100. To change the *Assume Low-End Calibration* range setting, refer to sections 4.1.1.6 for control panel access, or 4.1.2.16 for computer access to the user-setup menu.

3.2.1.2.2 Selecting HIGH Calibration Gas

The HIGH calibration gas may have an oxygen concentration anywhere above the upper limit of the *Assume Low End Calibration* range, and within the configured range of the model 7100 analyzer. For best accuracy, select a high calibration gas between ~80 % and ~120 % of the expected highest in-service reading, and within the allowable calibration gas limits (10 PPM – 1,000 PPM).

Reminder When selecting gases for two-point calibration, remember that one must be within the *Low End Calibration* range setting, and the other outside of that range. If none, or both selected calibration gases are within the *Low End Calibration* range, the model 7100 analyzer will not operate properly.

WARNING Calibrating the model 7100 on < 10 PPM oxygen concentration will cause the unit to operate improperly. Do not calibrate the model 7100 on zero-gas.

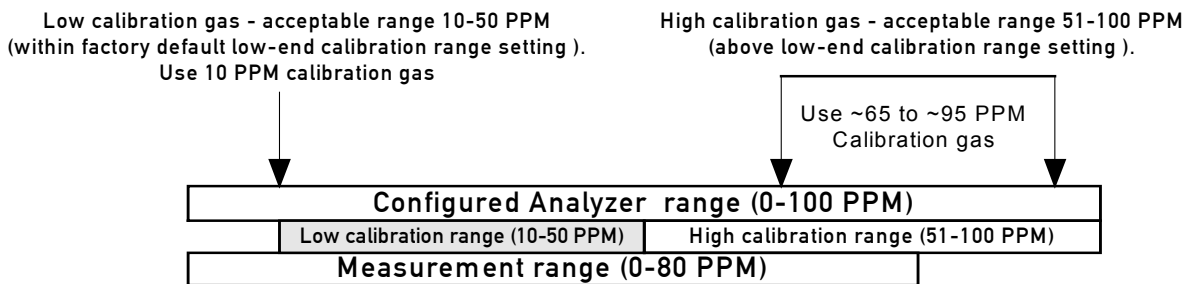

Figure 12 – Calibration gas selection example for Measurement range 0-80 PPM

3.2.1.3 CALIBRATION Step-2: Remove the Oxygen Sensor from Online Service

The oxygen sensor requires removal from on-line service to perform calibration. Calibration or other maintenance of the model 7100E analyzer and sensor should be performed when the measured process is not operating. If the unit has been installed with a Neutronics Inc process sampling system, please refer to the equipment manual for detailed instructions.

Warning Before opening any part of the sampling system to air, make sure that the sampling lines are not pressurized, and are clear of any gas that may create a personnel or environmental hazard.

Disconnect the measured process from the sensor by completely removing the installed 1/8" MNPT fittings from the sensor flow-through head sample inlet port (this step is not necessary if using a fixed gas manifold – section 2.3.1). If it is necessary to exhaust to an alternate path during calibration, completely remove the installed 1/8" MNPT fittings from the sensor flow-through head sample exhaust port. Connect the oxygen sensor to an alternate exhaust location as in section 2.1.2.3.

3.2.1.4 CALIBRATION Step-3: Apply LOW calibration gas to the Oxygen Sensor

Attach a pre-selected LOW calibration gas (section 3.2.1.2.1) to the sensor flow through head. The user may attach the regulated gas source to the sensor head sample inlet port directly, or through a fixed gas manifold. The latter method will help to prevent premature wear of tube-ends and fittings, and increase long-term sampling system integrity. Where a calibration manifold has not been installed, connect the calibration gas source to the oxygen sensor similar to section 2.1.2.2.

Apply calibration gas to the oxygen sensor. Adjust the regulated calibration gas pressure to match the pressure of the in-service sample gas, within the sensor pressure specification of 1-10 PSIG (Appendix B). Be sure to flow calibration gas to the sensor until the analyzer display has stabilized to allow calibration gas to sweep out the sample lines.

Warning: Never apply an unregulated gas supply to the oxygen sensor. High or uncontrolled pressures may damage the oxygen sensor, and/or sampling system components.

3.2.1.5 CALIBRATION Step-4: Calibrate the Model 7100E LOW

After a regulated stream of LOW calibration gas has been applied to the sensor, press and release the "MODE" key once. The 7-segment alphanumeric display will show "CAL", then an oxygen concentration value. Adjust the displayed oxygen concentration value to read the applied calibration gas oxygen concentration by pressing the "UP" or "DOWN" arrow key as required. Press and release the "MODE" key four times to return to Run mode.

3.2.1.6 CALIBRATION Step-5: Apply HIGH calibration gas to the Oxygen Sensor

Attach a pre-selected HIGH calibration gas (section 3.2.1.2.2) to the model 5100E sensor flow through head. The user may attach the regulated gas source to the sensor head sample inlet port directly, or through a fixed gas manifold. The latter method will help to prevent premature wear of tube-ends and fittings, and increase long-term sampling system integrity. Where a calibration manifold has not been installed, connect the calibration gas source to the oxygen sensor similar to section 2.1.2.2.

Apply calibration gas to the oxygen sensor. Adjust the regulated calibration gas pressure to match the pressure of the in-service sample gas, within the sensor pressure specification of 1-10 PSIG (Appendix B). Be sure to flow calibration gas to the sensor until the analyzer display has stabilized to allow calibration gas to sweep out the sample lines.

Analyzer Operation

3.2.1.7 CALIBRATION Step-6: Calibrate the Model 7100E HIGH

After a regulated stream of HIGH calibration gas has been applied to the sensor, press and release the “MODE” key once. The 7-segment alphanumeric display will show “CAL”, then an oxygen concentration value. Adjust the displayed oxygen concentration value to read the applied calibration gas oxygen concentration by pressing the “UP” or “DOWN” arrow key as required. Press and release the “MODE” key four times to return to Run mode.

3.2.1.8 CALIBRATION Step-7: Return the Oxygen Sensor to Online Service

When calibration procedures are complete, the model 7100E is ready to return to service. Disconnect calibration gas from the oxygen sensor by completely removing the installed 1/8” FNPT fitting from the sensor flow-through head sample inlet port. Where a calibration manifold has not been installed, reconnect the sample inlet port to the process for in-service oxygen measurement (section 2.1.2.2). If an alternate vent connection has been made, reconnect the sensor flow-through head sample exhaust port to the primary vent source (section 2.1.2.3). Be sure to flow sample gas to the sensor until the analyzer display has stabilized to allow time to sweep the sample lines clear of calibration gas.

3.2.2 SET/VIEW ALARM-1 Mode

To enter Set Alarm-1 mode from run mode using the keypad; scroll through the user mode menu by pressing momentarily the “MODE” key two (2) times, until the 7-segment alphanumeric display reads “AL1” (set alarm-1 level), and the “RUN” and “ALM1” indicator LED’s flash. The display will show momentarily “AL1” and then the current alarm-1 threshold level (an O₂ concentration). Use the “UP” and “DOWN” keys to adjust the alarm-1 setpoint level. Changed settings are automatically saved when the “MODE” key is pressed to enter the next mode.

3.2.3 SET/VIEW ALARM-2 Mode

To enter Set Alarm-2 mode from run mode using the keypad; scroll through the user mode menu by pressing momentarily the “MODE” key three (3) times, until the 7-segment alphanumeric display reads “AL2” (set alarm-2 level) and the “RUN” and “ALM2” indicator LED’s flash. The display will show momentarily “AL2” and then the current alarm-2 threshold level (an O₂ concentration). Use the “UP” and “DOWN” keys to adjust the alarm-2 setpoint level. Changed settings are automatically saved when the “MODE” key is pressed to enter the next mode.

3.2.4 VIEW ACTIVE FAULTS Mode

To enter View Active Faults mode from run mode using the keypad; scroll through the user mode menu by pressing momentarily the “MODE” key four (4) times until the 7-segment alphanumeric display reads “FL”, and the “RUN” and “FAULT” indicator LED’s flash. The display will show momentarily “FL” and then the highest priority active system fault. Press and release the “UP” or “DOWN” key to scroll through all active system faults. Refer to section 4.3.1 for a complete fault code listing, and troubleshooting guide. To exit, press and release the “MODE” key.

3.2.5 Return to RUN Mode

To exit to run mode from any user mode, using the keypad; scroll through the control panel user mode menu by pressing repeatedly the “MODE” key until the 7-segment alphanumeric display shows “run”. The display will then show an oxygen concentration. The “RUN”, “ALM1”, “ALM2”, and “FAULT” LED’s will flash for 120 seconds to indicate that the analyzer is in a stabilization period. This is to allow time to sweep the sample lines with sample gas before returning the unit to on-line service. During the stabilization period, alarm-1, alarm-2, and fault, relays remain inactive, and held to their last state before the control panel user mode menu was accessed.

3.3 System Modes

The model 7100E has five System modes – Self-Test & warm-up, Run, Alarm-1 Active, Alarm-2 Active, or Fault Active. Self-Test & Warm-up are fixed routines that are initiated upon each start-up. The remaining system modes, provided no valid manual input is received at the control panel or service port, are initiated automatically by the analyzer according to setup parameters entered by the user in Setup mode, compared against monitored inputs and other monitored system hardware in real time.

3.3.1 Self-Test & Warm-up Mode

When the model 7100E is started up, it enters into Self-Test & Warm-up mode automatically (section 2.2.1). When the analyzer self-test is complete, the unit checks the current sensor signal, updates the 7-segment LED display, status LED’s, and Analog outputs, then enters into the appropriate system mode according to its programmed parameters.

3.3.2 RUN Mode

The model 7100E initiates Run mode when it is continuously measuring the oxygen concentration of the in-service sample gas, and updating the display and outputs accordingly, and it has not detected any valid user input. A solid lit or flashing “RUN” indicator LED indicates to the user that the instrument is on-line, and the system is operating properly.

When the measured process oxygen concentration falls outside of programmed alarm parameters, and/or the system experiences a fault condition, the model 7100E analyzer enters into Alarm-1 Active, Alarm-2 Active, and/or Fault Active mode accordingly. The system does not abort Run mode, and the “RUN” indicator LED stays lit. The appropriate indicator LED will light in addition to the “RUN” indicator LED.

When programmed alarm setpoints and/or fault conditions are cleared, the model 7100E analyzer aborts Alarm-1 Active, Alarm-2 Active, and/or Fault Active mode accordingly. The system does not abort Run mode, and the “RUN” indicator LED stays lit. Indicator LED’s mapped to aborted modes go out.

When the model 7100E analyzer detects valid user-input, it enters into one of the user modes accordingly – Calibration, Set/View Alarm-1, Set/View Alarm-2, View Active Faults, or User Setup. The analyzer aborts Run mode and holds the state of Alarm-1, Alarm-2, and Fault. The “RUN” indicator LED goes out, except in Calibrate mode, where it flashes.

When the user manually aborts all user modes by returning the system to Run mode, or no valid user input is detected for 120-seconds, the model 7100E checks the current sensor signal, updates the 7-segment LED display, status LED’s, and Analog outputs, then enters into the appropriate system mode according to its programmed parameters. Alarm-1, Alarm-2, and Fault relay outputs are released and the “RUN” indicator LED is lit.

Analyzer Operation

3.3.3 ALARM-1 ACTIVE Mode

The model 7100E initiates Alarm-1 Active mode when it has detected that the measured oxygen concentration has exceeded the set threshold value of Alarm-1 (section 3.2.2). The “ALM1” indicator LED will light, The “RUN” indicator LED will remain lit. The Alarm-1 relay will change state according to the analyzer configuration (Appendix C, Factory Setup). The Alarm status will be cleared automatically when the measured oxygen concentration is within the set threshold value of Alarm-1. The “ALM1” indicator LED will go out, and the Alarm-1 relay will return to its non-active state according to the analyzer configuration. The Alarm-1 Active mode is held to its last state during manual access to the user mode menu.

3.3.4 ALARM-2 ACTIVE Mode

The model 7100E initiates Alarm-2 Active mode when it has detected that the measured oxygen concentration has exceeded the set threshold value of Alarm-2 (section 3.2.3). The “ALM2” indicator LED will light, The “RUN” indicator LED will remain lit. The Alarm-2 relay will change state according to the analyzer configuration (Appendix C, Factory Setup). The Alarm status will be cleared automatically when the measured oxygen concentration is within the set threshold value of Alarm-2. The “ALM2” indicator LED will go out, and the Alarm-2 relay will return to its non-active state according to the analyzer configuration. The Alarm-2 Active mode is held to its last state during manual access to the user mode menu.

3.3.5 FAULT ACTIVE Mode

The model 7100E initiates Fault Active mode when it has detected that one or more Fault criterion have been satisfied (section 4.3.1). The “FAULT” indicator LED will light and the Fault relay will change state. The Fault status will be cleared automatically when no Fault criterion have been satisfied. The “FAULT” indicator LED will go out and the Fault relay will return to its non-active state. The user may view active faults at any time from the control panel (section 3.2.4).

4 CHAPTER 4 – MAINTENANCE AND TROUBLESHOOTING

4.1 System Setup

The model 7100E is shipped ready to install and operate with complete factory configuration already programmed and tested. The user may however wish to change the system configuration to suit the application of the analyzer. Some setup parameters may be changed by the user via the control panel keypad. All configuration parameters may be changed by the user via the Service Port.

Important: Before changing any of the model 7100E settings, refer to Appendix C – Factory Setup for reference. If the user has any questions before proceeding with changing analyzer settings, please contact the Neutronics Ntron division Service Department for assistance.

4.1.1 System Setup via Control panel Keypad

The control panel user setup menu may be accessed from the model 7100E control panel by pressing and holding the “MODE” key for at least 10-seconds until the 7-segment alphanumeric display shows “---” to indicate that the analyzer has accessed setup mode. Release the “MODE” key to activate setup mode. Once in setup mode, the user can access adjustable parameters sequentially by continuing to press and release the “MODE” key to scroll through the setup menu.

When you reach the mode that you wish to change, use the “UP” and “DOWN” keys to adjust the displayed setting. The modes are numerically identified by the number on the left side of the display. The current mode setting is identified by the number on the right side of the display. The new settings are automatically saved when the user advances to the next mode by pressing and releasing the “MODE” key. The user may exit the Setup menu at any time by pressing simultaneously the “UP” and “DOWN” keys (Appendix D, Control panel Hot-Key functions).

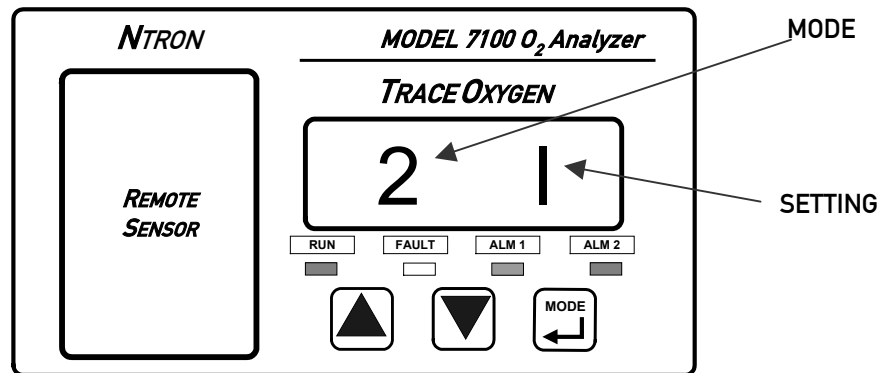

4.1.1.1 User Setup A: Display Range Select

This parameter allows the user to map the display and electrical output range scale of the model 7100E to suit the application (Appendix E – Range / Output Chart).

Valid Settings: 1 (fixed range 0-10 PPM) • 2 (fixed range 0-100 PPM) • 3 (fixed range 0-1000 PPM) • 4 (fixed range 0-2000 PPM) • 8 (full auto-range)

Maintenance and Troubleshooting

4.1.1.2 User Setup 1: Alarm-1 Relays Ascending/Descending Action

This parameter allows the user to set the Alarm-1 relay action to *ascending* (the relay is set to its active state when the oxygen level is above the Alarm-1 level set point) or to *descending* (the relay is set to its active state when the oxygen level is below the Alarm-1 level set point).

Valid Settings: 0 (Descending) • 1 (Ascending)

4.1.1.3 User Setup 2: Alarm-2 Relays Ascending/Descending Action

This parameter allows the user to set the Alarm-2 relay action to *ascending* (the relay is set to its active state when the oxygen level is above the Alarm-2 level set point) or to *descending* (the relay is set to its active state when the oxygen level is below the Alarm-2 level set point).

Valid Settings: 0 (Descending) • 1 (Ascending)

4.1.1.4 User Setup 3: Analog Voltage Output Setting

This parameter allows the user to set the Analog Output Voltage full scale to 1, 5, or 10 volts. *Note that the software settings must match the RA and RB jumper settings on the Main CPU PCB* (section 4.1.3).

Valid Settings: 0 (0-5 VDC) • 1 (0-10 VDC), 2 (0-1 VDC)

4.1.1.5 User Setup 4: Serial Output Format

This parameter allows the user to set the RS-232 communications timed output format.

Valid Settings: 0 (Output on Request) • 1 (Human Readable) • 2 (Machine Code) • 3 (Machine Code with Checksum) • 4 (Tab Delimited)

4.1.1.6 User Setup 7: Set Assume Low-End Calibration Range Code

The zero calibration range code allows the user to set the “low-span” calibration concentration range for the model 7100E two-point calibration system. During calibration, the model 7100E analyzer will recognize an applied calibration gas as a “zero-range” calibration gas without further user action if its oxygen concentration is within the range set in by zero calibration code. Refer to section 3.2.1 for a detailed explanation of the calibration system.

Valid Settings: 0 (single point calibration) • 3 (0-5 PPM) • 4 (0-50 PPM) • 5 (0-500 PPM)

4.1.1.7 User Setup F: Alarm-1 and Alarm-2 Relays Failsafe/Non Failsafe Action

This parameter allows the user to set the Alarm-1 and Alarm-2 relays to either *failsafe* action (relay coils not powered in active alarm state) or *non-failsafe* (relay coils powered in active alarm state).

Valid Settings: 0 (Non-Failsafe) • 1 (Failsafe)

4.1.1.8 User Setup B: RS-232 Baud Rate

This parameter allows the user to set the RS-232 communications baud rate.

Valid Settings: 1 (300BPS) • 2 (1200BPS) • 3 (2400BPS) • 4(4800BPS) • 5 (9600BPS)
6 (19200BPS) • 7 (38400BPS)

4.1.1.9 User Setup 8: Factory Setup Restore.

This parameter allows the user to return the model 7100E to its initial factory-commissioned settings. Always perform a gas calibration after restoring factory settings.

Valid Settings: 88. A setting of 88 will activate the Factory Setup restore.

4.1.2 System Setup via Service Port

The model 7100E analyzer features a Service Port, which is accessible for programming the system, monitoring the analyzer output, and determining active fault codes for troubleshooting. The Service Port has been designed for communication with a PC based computer or other device capable of receiving and transmitting ASCII data packets over a standard RS-232 serial interface.

Access to the Serial Service Port may be made through a terminal emulator program such as **HyperTerminal**, available in Microsoft Windows 95 or later:

4.1.2.1 RS-232 Service Port Interfacing with HyperTerminal in Microsoft Windows 95 or later

Turn off your PC computer, and remove power from the Model 7100E. Complete the instructions for wiring and connecting the model 7100E to a PC computer (section 2.1.3.10). Apply power to the model 7100E, and start up the PC computer.

On your PC computer, open HyperTerminal: Navigate from the Windows desktop – Select **Start** → **Programs** → **Accessories** → **Communications** → **HyperTerminal**

In HyperTerminal, create and configure a new connection – follow the prompts:

PROMPT	YOU ENTER
CONNECTION NAME	7100E
CONNECT TO	COM1, or other available COM port

In HyperTerminal, select the correct COM port properties, to interface properly with the model 7100E:

PROPERTIES	YOU ENTER
BITS PER SECOND	9600
DATA BITS	8
PARITY	None
STOP BITS	1
FLOW CONTROL	None
TERMINAL EMULATION	VT 100 *

* Not all versions of MS Windows prompt for this parameter.

Select “Apply” and “OK” as prompted. The Hyper Terminal program will immediately begin communicating with the model 7100E, and the model 7100E will commence sending data via ASCII code dump to the PC. The information from the analyzer will be sent in ASCII strings, at 1-second intervals. Data will be sent in the factory default “Human Readable” format.

Maintenance and Troubleshooting

4.1.2.2 Troubleshooting Your HyperTerminal Interface

If serial communications with the model 7100E fails, isolate the problem by performing the following tests:

Disconnect the RS-232 cable from the model 7100E by removing the terminal block connector from TB3. Insert a jumper between pins 9 & 10 on the terminal block connector. Enter a few letters from the PC keyboard. The PC monitor should display the corresponding alpha-characters as they are typed. If the letters do not display on the monitor screen, there is a problem with the RS-232 cable, the PC serial COM port, or the HyperTerminal setup.

If the typed letters DO show on the monitor screen and serial communications with the model 7100E still has not been established, then PC COM port pins 2 & 3 (7100E pins 9 & 10) may be reversed. Verify the cable wiring (section 2.1.3.10). If no transmitted data from the model 7100E is seen on the monitor screen, call the Neutronics Inc. Service Department for further assistance.

4.1.2.3 Organization of RS-232 Serial Data

There are three levels of access through the service port that can be used for interfacing with the model 7100E:

Standard Access: ASCII dump to a PC, printer, or DAQ, and provides basic operator access.

Advanced Level-1 Access: Allows user setup and configuration, such as alarms, and data format.

Advanced Level-2 Access: Allows access to vital control areas via password.

4.1.2.4 Standard Level Access

Standard Level Access is the default level of access to the model 7100E available to the user via a host computer or printer over a standard RS-232 serial interface. In Standard Level access, the user can make inquiries about oxygen concentration, sensor signal level, and other parameters for system servicing, and troubleshooting.

When communications are established between the model 7100E and a host computer, 2-way communication begins automatically in Standard Level access. Data is sent out the analyzer RS-232 Service Port to the host terminal once-per-second, in the factory-default Human Readable format (section 4.1.2.4.2). There are no commands necessary to begin viewing information transmitted by the model 7100E in Standard Level access.

To request and view specific information via the RS-232 interface, type the desired command key selected from the Standard Access level command chart below (It is not necessary to press return).

Helpful Hint: For viewing convenience, before requesting specific information from the model 7100E, disable automatic 1-second updates from the model 7100E and allow access of information by-request-only (section 4.1.2.4.1), by typing "SSERFMT=0", followed by the Return key. To return to automatic 1-second updates of data from the analyzer in Human Readable format (section 4.1.2.4.2), type "SSERFMT=1", followed by the Return key.

The STANDARD ACCESS level commands**TYPED COMMAND DESCRIPTION OF QUERIED FUNCTION**

A	Short software version
C	Analyzer Model number
E	Sensor output in Percent Oxygen
G	Sensor output in Volts
H	Active Fault codes
I	Active Fault code descriptions
V	Long software version
@	Unit Serial Number

There are several data formats of the ASCII data dump available. They may be changed from Standard Level Access to suit the user's needs as follows:

TYPED COMMAND DESCRIPTION OF QUERIED FUNCTION

SSERFMT=0	Disables RS-232 continuous periodic data-dump
SSERFMT=1	Enables RS-232 output in HUMAN READABLE format
SSERFMT=2	Enables RS-232 output in MACHINE format w/o Checksum
SSERFMT=3	Enables RS-232 output in MACHINE format w/Checksum
SSERFMT=4	Enables RS-232 output in TAB DELIMITED (Excel) format
SCALIBRATE=.XXXXXX	The user can send a calibration value in decimal format where 100 % Oxygen = 1. The number format entered must be 6-decimal places.

4.1.2.4.1 Disable RS 232 continuous output – SSERFMT=0

The factory default 1-second data-dump in Standard Level access can be disabled through the RS-232 interface in Standard Access level. While this setting is active, the user must request information by pressing the desired key according to the STANDARD ACCESS level commands chart.

4.1.2.4.2 Human Readable Data Format – SSERFMT=1

The factory default format is Human Readable and can be changed via the analyzer control panel, or through the RS-232 interface in Standard Level Access. Human Readable data is presented in dynamic columns (columns appear only when data is present). It is intended for most users, to aid in setup and maintenance of the unit. Column headings from left to right: **Mode • O₂ Concentration • Alarm-1 status • Alarm-1 status • list of Fault codes active.**

4.1.2.4.3 Machine Data Format with NO Checksum

Machine format with NO checksum can be selected via the analyzer control panel, or through the RS-232 interface in Standard Access level. Machine format with NO checksum data is streamed in packets defined by start/stop transmit bits. The order of data in each packet is as follows: **Start Transmit • O₂ Concentration • Fault codes active • List of Fault Codes • Alarm-1 status • Alarm-1 status • End Transmit.** For detailed information on data formats, please contact the Neutronics Service Department.

Maintenance and Troubleshooting

4.1.2.4.4 Machine Data Format WITH Checksum

Machine format with checksum can be selected via the analyzer control panel, or through the RS-232 interface in Standard Access level. Machine format with checksum data is streamed in packets defined by start/stop transmit bits. The order of data in each packet is as follows: **Start Transmit • O₂ Concentration • Fault codes active • List of Fault Codes • Alarm-1 status • Alarm-2 status • Checksum • End Transmit**. For detailed information on data formats, please contact the Neutronics Service Department.

4.1.2.4.5 Tab delimited Data Format

Tab delimited format can be selected via the analyzer control panel, or through the RS-232 interface in Standard Access level. Tab delimited data is presented in static columns (the same number of columns is always transmitted in a complete data message). Column headings from left to right: **Time since last re-boot^{tab} • Mode^{tab} • O₂ Concentration^{tab} • Alarm-1 status^{tab} • Alarm-2 status^{tab} • list of Fault codes active^{tab}**. For detailed information on data formats, please contact the Neutronics Service Department.

4.1.2.5 Advanced Level 1 Access

Advanced Level-1 access is the computer-interfaced user Setup mode. Access to Advanced Level-1 can be accomplished on a PC by typing “setup” when viewing the Human Readable ASCII output. The User Setup menu will be displayed on the PC screen allowing access for changing the system setup.

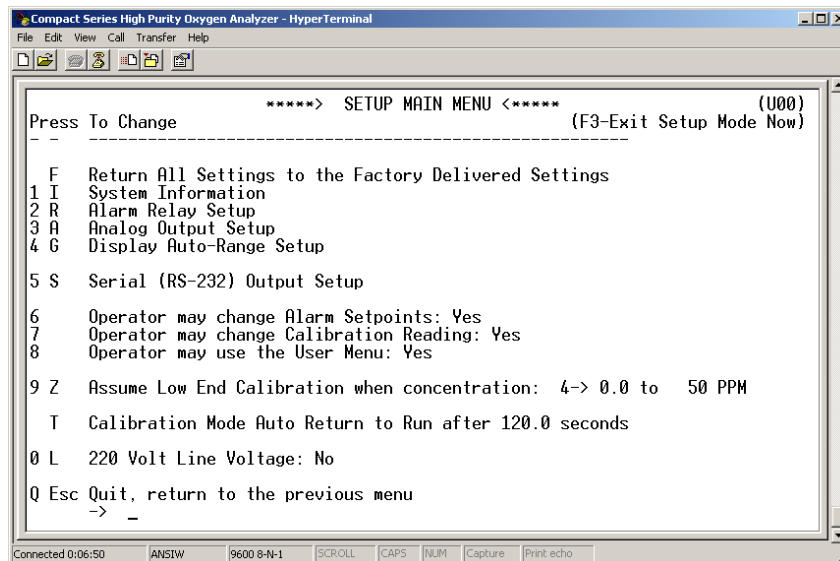

Figure 14 – Level-1 Access (SETUP) Mode Menu

4.1.2.6 Advanced Level-2 Access

Advanced Level-2 access is available to the user via a PC only by use of a password. This level of access allows the manipulation of all code settings. Contact the Neutronics Inc. Service Department for support before attempting to use Advanced Level-2 access.

4.1.2.7 SETTING UP THE MODEL 7100E – The RS-232 User Setup Menu

The RS-232 User Setup menu U00 is the “Home” screen in Advanced Level-1 access (section 4.1.2.5), and provides access to all the parameters that may need to be adjusted by the user. The interactive menu is initiated by typing “setup” and pressing the "Enter" key on the RS-232 terminal; as in entering Advanced Level-1 access. To navigate backwards, use the <Esc> or “Q” key on the RS-232 terminal.

4.1.2.8 Return all Settings to Factory Delivered Settings

In case of severe corruption of calibration and setting information, this setting will allow the user to restore the model 7100E analyzer to its “out-of-box” setting. The user may type “Y” at the prompt to initiate a restore, or “N” and the prompt to bypass a restore. This setting is accessed from the Setup Main Menu by typing “F” on the RS-232 Terminal. To navigate backwards, use the <Esc> or “Q” key on the RS-232 terminal.

4.1.2.9 System Information Display

The System Information Display **U10** is a list of all the current settings for the model 7100E analyzer. It is accessed from the Setup Main Menu by typing “1” or “I” on the RS-232 Terminal.

4.1.2.10 (U20) Alarm Relay Setup Menu

The RS-232 Alarm/Relay Setup menu **U20** provides access to all of the settings related to the alarms, controls, and relays on the model 7100E analyzer. It is accessed from the Setup Main Menu by typing “2” or “R” on the RS-232 Terminal. To navigate backwards, use the <Esc> or “Q” key on the RS-232 terminal.

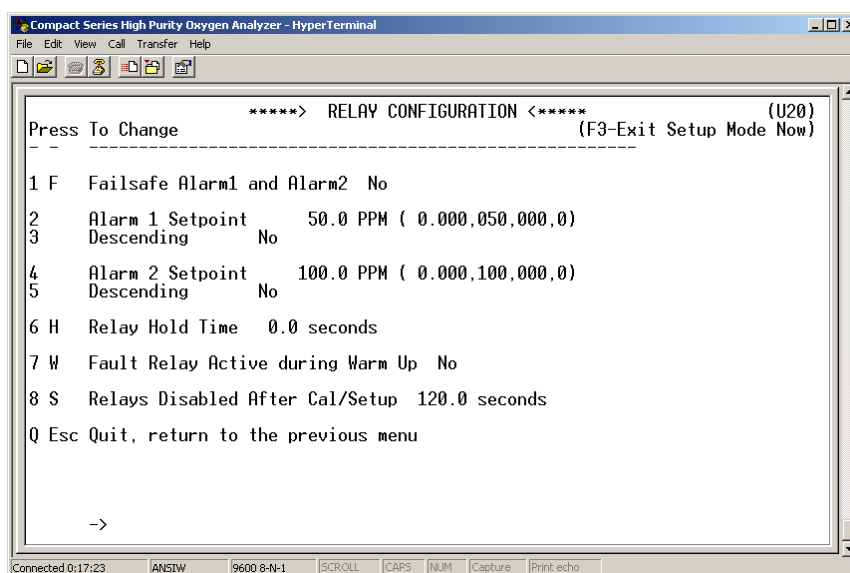

Figure 15 – Relay Configuration Menu

4.1.2.10.1 Alarm-1 and Alarm-2 Relays Failsafe

This parameter allows the user to set the Alarm-1 and Alarm-2 relays to either *failsafe* or *non-failsafe* action. *Failsafe* action is defined as; relay coils are not powered (contacts are in *normal* position) in active alarm state. *Non-Failsafe* action is defined as; relay coils are powered (contacts are in *non-normal* position) in active alarm state. The Alarm-1 and Alarm-2 Relays Failsafe setting may be set to “YES” or “NO”. This setting is accessed from the Alarm and Relay Setup Menu by typing “1” or “F” on the RS-232 terminal.

4.1.2.10.2 Alarm-1 Level Setting (setpoint)

This setting sets the threshold level for Alarm-1. Depending on whether or not it is set to ascending or descending, Alarm-1 becomes active when the oxygen concentration is above or below this threshold level. The Alarm-1 setpoint may be set anywhere from 0 PPM to 2,000 PPM. This setting is accessed from the Alarm Relay Setup Menu by typing “2” on the RS-232 terminal.

Maintenance and Troubleshooting

4.1.2.10.3 Alarm-1 Descending

This setting configures Alarm-1 to either ascending or descending action. Ascending is defined as Alarm-1 active when the oxygen concentration is above the Alarm-1 setpoint level. Descending is defined as; Alarm-1 active when the oxygen concentration is below the alarm-1 setpoint level. The descending setting may be set to "YES" or "NO". This setting is accessed from the Alarm and Relay Setup Menu by typing "3" on the RS-232 terminal.

4.1.2.10.4 Alarm-2 Level Setting (setpoint)

This setting sets the threshold level for Alarm-2. Depending on whether or not it is set to ascending or descending, Alarm-2 becomes active when the oxygen concentration is above or below this threshold level. The Alarm-2 setpoint may be set anywhere from 0 PPM to 2,000 PPM. This setting is accessed from the Alarm Relay Setup Menu by typing "4" on the RS-232 terminal.

4.1.2.10.5 Alarm-2 Descending

This setting configures Alarm-2 to either ascending or descending action. Ascending is defined as Alarm-2 active when the oxygen concentration is above the Alarm-2 setpoint level. Descending is defined as; Alarm-2 active when the oxygen concentration is below the alarm-2 setpoint level. The descending setting may be set to "YES" or "NO". This setting is accessed from the Alarm and Relay Setup Menu by typing "5" on the RS-232 terminal.

4.1.2.10.6 Relay Hold Time

This setting determines the minimum time that Alarm-1 and Alarm-2 relays will hold their active state once the Alarm-1 and Alarm-2 setpoint levels have been exceeded, regardless of the actual Oxygen concentration after Alarm-1 and Alarm-2 have been activated. The Hold Time level may be set anywhere from 0 to 300 seconds. This setting is accessed from the Alarm Relay Setup Menu by typing "6" or "H" on the RS-232 terminal.

4.1.2.10.7 Fault Relay Active during Warm-up

This setting determines the active status of the Fault relay during the Model 7100E warm-up routine (section 4.3.1.2). The activate setting may be set to "YES" or "NO". This setting is accessed from the Alarm Relay Setup Menu by typing "7" or "W" on the RS-232 terminal.

4.1.2.10.8 Relays Disabled after CAL/Setup

This setting determines the time that relays will be held in their last state before returning to Run mode from the control panel or service port user menus. The relays disabled time may be set anywhere from 0 to 14,400 seconds. This setting is accessed from the Alarm Relay Setup Menu by typing "8" or "S" on the RS-232 terminal.

4.1.2.11 (U30) Analog Output Setup Menu

The RS-232 Analog Output Setup menu **U30** provides access to all of the settings related to the Analog Voltage Output (TB3-Pin 5, TB3-Pin 6) and Analog Current Output (TB3-Pin 7, TB3-Pin 8). It is accessed from the Setup Main Menu by typing “3” or “A” on the RS-232 terminal. To navigate backwards, use the <Esc> or “Q” key on the RS-232 terminal.

```

Compact Series High Purity Oxygen Analyzer - HyperTerminal
File Edit View Call Transfer Help
*****> ANALOG CONFIGURATION <***** (U30)
Press To Change (F3-Exit Setup Mode Now)
-----
1 J Voltage Output: Hardware Range Jumpers
   '2->Jumper RA-OUT RB-IN 0.0 .. 1.0 V'
2 I Current Output Range: 1 ->4.0 to 20.0 mA
3 M Use Manual Analog Output Ranges No
   --- Manual Analog Output Range Configuration ---
4 VOut = 0 Volts when 0.0 PPM ( 0.000,000,000,0)
5 VOut = Full Scale when 1000000.0 PPM ( 1.000,000,000,0)
6 IOut = Low Scale when 0.0 PPM ( 0.000,000,000,0)
7 IOut = 20.0 mA when 1000000.0 PPM ( 1.000,000,000,0)
0 Esc Quit, return to the previous menu

->
Connected 0:19:46 ANSIW 9600 8-N-1 SCROLL CAPS NUM Capture Print echo

```

Figure 16 – Analog Output Configuration Menu

4.1.2.11.1 Analog Voltage Output Range

This menu sets the Analog Voltage Output full-scale value. It may be set to 0 (0-5 VDC minimum to full scale), 1 (0-10 VDC minimum to full scale) or 2 (0-1 VDC minimum to full scale). This setting must match the RA and RB hardware jumper settings on the bottom of the main CPU PCB (section 4.1.3). This menu is accessed from the Analog Output Setup menu by typing “1” or “J” on the RS-232 terminal.

4.1.2.11.2 Analog Current Output Range

This menu sets the Analog Current Output range. It may be set to 0 (0-20mA minimum to full scale), or 1 (4-20mA minimum to full scale). This menu is accessed from the Analog Output Setup menu by typing “2” or “I” on the RS-232 terminal.

4.1.2.11.3 Use Manual Analog Output Ranges

This menu is used to enable manual override of Analog output mapping to display range, and to force minimum and maximum Analog outputs to absolute Oxygen measurement values. This menu is accessed from the Analog Output Setup menu by typing “3” or “M” on the RS-232 terminal.

4.1.2.11.4 Force minimum Voltage Output to O₂ Concentration

This menu sets the Oxygen concentration at which the Analog Voltage output is at zero. This setting is entered in PPM increments, and can be anywhere from 0 PPM to 2,000 PPM. This menu is accessed from the Analog Output Setup menu by typing “4” on the RS-232 terminal.

Maintenance and Troubleshooting

4.1.2.11.5 Force Maximum Voltage to O₂ Concentration

This menu sets the oxygen concentration at which the Analog Voltage output is at maximum range (section 4.1.2.11.1). This setting is entered in PPM increments and can be anywhere from 0 PPM to 2,000 PPM. This menu is accessed from the Analog Output Setup menu by typing “5” on the RS-232 terminal.

4.1.2.11.6 Force minimum Current Output to O₂ Concentration

This menu sets the Oxygen concentration at which the Analog Current output is at minimum range (section 4.1.2.11.2). This setting is entered in PPM increments and can be anywhere from 0 to 2,000. This menu is accessed from the Analog Output Setup menu by typing “6” on the RS-232 terminal.

4.1.2.11.7 Force Maximum Current Output to O₂ Concentration

This menu sets the Oxygen concentration at which the Analog Current output is at maximum range (section 4.1.2.11.2). This setting is entered in PPM increments and can be anywhere from 0 PPM to 2,000 PPM. This menu is accessed from the Analog Output Setup menu by typing “7” on the RS-232 terminal.

4.1.2.12 (U14) Display/Auto-Range Setup

The RS-232 Display/Auto-Range Setup menu **U14** provides access for the user to map the display and Analog output range scale(s) of the Model 7100E to suit the application (Appendix E – Range / Analog output Chart). The Analog Output Range may be set to 1 (fixed range 0-10 PPM) • 2 (fixed range 0-100 PPM) • 3 (fixed range 0-1000 PPM) • 4 (fixed range 0-2000 PPM) • 8 (full auto-range). This menu is accessed from the Setup Main Menu by typing “4” or “G” on the RS-232 terminal. To navigate backwards, use the <Esc> or “Q” key on the RS-232 terminal.

4.1.2.13 (U50) RS-232 Serial Setup Menu

This menu provides access to set the RS-232 serial communications options. It is accessed from the Setup Main Menu by typing “5” or “S” on the RS-232 terminal. To navigate backwards, use the <Esc> or “Q” key on the RS-232 terminal.

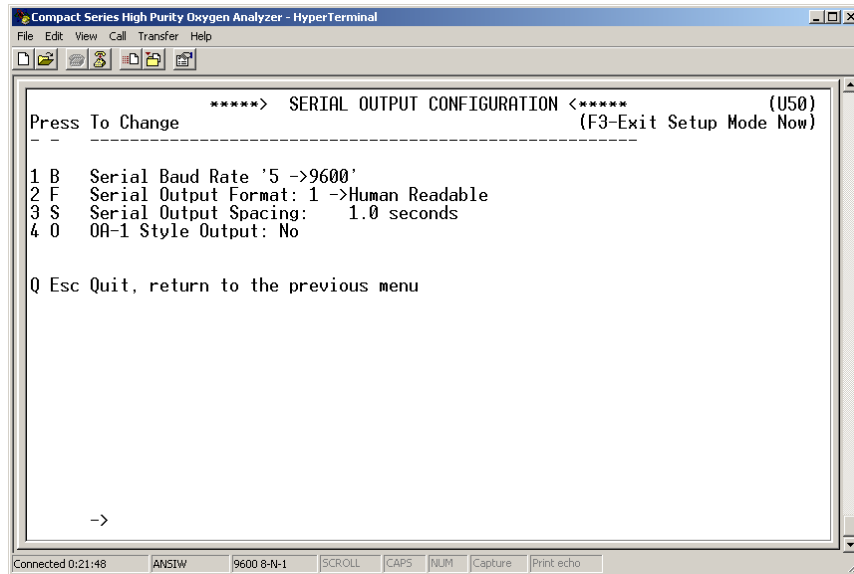

Figure 17 – Serial Output Configuration Menu

4.1.2.13.1 Baud Rate

This menu sets the RS-232 baud rate. The baud rate can be set to 1 (300BPS), 2 (1200BPS), 3 (2400BPS), 4 (4800BPS), 5 (9600BPS), 6 (19200BPS) or 7 (38400BPS). This menu is accessed from the RS-232 Serial Setup menu by typing "1" or "B" on the RS-232 terminal.

4.1.2.13.2 Automatic Serial Output Format

This menu sets the format of the automatic timed RS-232 serial output (section 4.1.2.4). The timed serial output format may be set to 0 (Output on Request), 1 (Human Readable), 2 (Machine Code), 3 (Machine Code with Checksum), 4 (Tab delimited) 5 (OA1 style; not used). This menu is accessed from the RS-232 Serial Setup menu by typing "2" or "F" on the RS-232 terminal.

4.1.2.13.3 Serial Output Spacing

This menu sets the rate at which the RS-232 sends complete ASCII data packets to the Service Port. The send rate can be set anywhere from 1 to 86,400 seconds (24-hours). This menu is accessed from the RS-232 Serial Setup menu by typing "3" or "S" on the RS-232 terminal.

4.1.2.13.4 OA1 Style Output – NOT USED**4.1.2.14 Alarm Setpoint Lockout**

If the Alarm Setpoint Lockout is enabled, the user may not change, but only view the Alarm-1 and Alarm-2 level settings. The Alarm Lockout setting is accessed from the Setup Main Menu by typing "6" on the RS-232 terminal. To navigate backwards, use the <Esc> or "Q" key on the RS-232 terminal.

4.1.2.15 Gas Calibration Lockout

If the Gas Calibration Lockout is enabled, the user may not change, but only view the Gas Calibration value. The Gas Calibration Lockout setting is accessed from the Setup Main Menu by typing "7" on the RS-232 terminal. To navigate backwards, use the <Esc> or "Q" key on the RS-232 terminal.

4.1.2.15.1 User Menu Lockout

If the Front Menu Lockout is enabled the user may not manually initiate any User mode from the control panel. The User Menu Lockout setting is accessed from the Control panel Locks menu by typing "8" on the RS-232 terminal. To navigate backwards, use the <Esc> or "Q" key on the RS-232 terminal.

4.1.2.16 Assume Low-End Calibration

The Assume Low-End Calibration range code (Zero Calibration Range in the setup menu) allows the user to set the range of acceptable LOW calibration gas for the model 7100E two-point calibration system. During calibration, the model 7100E analyzer will automatically recognize an applied calibration gas as a LOW range calibration gas if its oxygen concentration is within the range set by the Assume Low-End Calibration range code. Refer to section 3.2.1 for a detailed explanation of the calibration system. Assume Low-End Calibration range can be set to 0 (single point calibration) • 3 (0-5 PPM) • 4 (0-50 PPM) • 5 (0-500 PPM). The Assume Low-End Calibration setting is accessed from the Setup Main Menu by typing "9" on the RS-232 terminal. To navigate backwards, use the <Esc> or "Q" key on the RS-232 terminal.

4.1.2.16.1 Calibration Mode Auto Return to RUN

This setting determines the minimum time that the Model 7100E allows after exiting from control panel or service port user menus, before returning the unit to on-line status. The calibration mode auto return setting is accessed from the Control panel Locks menu by typing "T" on the RS-232 terminal. To navigate backwards, use the <Esc> or "Q" key on the RS-232 terminal.

4.1.2.17 220 Volt Line Voltage - NOT USED

Maintenance and Troubleshooting

4.1.3 Change factory settings via Hardware Jumpers

4.1.3.1 Analog Voltage Output

The Analog voltage output must be configured using the hardware settings. In addition, the software settings must match the jumper settings. Software changes are made via the Control panel User Setup menu (section 4.1.1), or the Service Port RS-232 User Setup menu (section 4.1.2.7).

4.1.3.1.1 Remove the unit from service

Make certain that all interfacing to the model 7100E is disabled at the user device. Make sure that interrupting outputs, from the unit will not interfere with normal process monitoring or control. Disconnect power from the model 7100E unit. Disconnect the removable terminal blocks from the rear of the model 7100E chassis. Follow all lock-out/tag-out procedures.

4.1.3.1.2 Change jumper settings

Turn the model 7100E upside down to access the jumpers through the port provided. Identify the appropriate jumper position. Use an insulated jumper-puller to remove and replace jumpers (Figure 12).

4.1.3.1.3 Return to service

Replace cables, and terminal blocks. Reapply power. Change Analog Voltage Output setting from control panel or service port to match new hardware settings. Perform a calibration check. Check function of changes to ensure the new settings are recognized by the model 7100E.

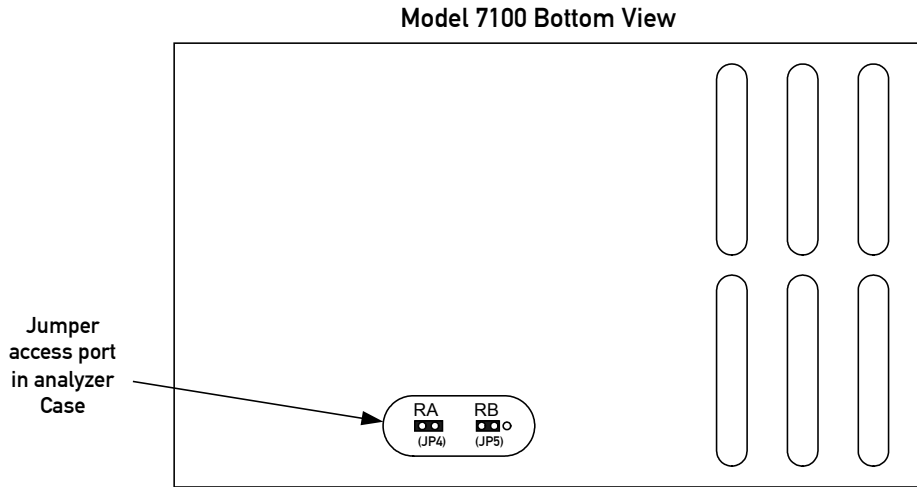

Figure 18 – Range select jumpers

JP4 / JP5 JUMPERS (1=SHORTED; 0=OPEN)		SELECT VOLTAGE OUTPUT RANGE
RA	RB	
0	1	$V_{out} = 0-1$ VDC
0	0	$V_{out} = 0-5$ VDC
1	0	$V_{out} = 0-10$ VDC

Figure 19 – Range select jumper settings

4.2 Routine Periodic Maintenance

Maintenance for the Model 7100E Oxygen analyzer is very simple. Apart from the normal maintenance for any instrument, such as cleaning the chassis, wiping the display, and replacing the sensor, the Model 7100E does not require any major periodic servicing. Calibration of the sensor on a known gas source should be performed on a regular basis. The chart below should serve as a general guide for maintenance personnel.

TASK	RECOMMENDED FREQUENCY		
	AT COMMISSIONING	EVERY YEAR	AS REQUIRED
Calibrate Sensor	√		√
Clean the analyzer chassis and display panel with soft cloth. Make sure the ventilation ports are clear.		√	√
Configure alarms	√		√
Check the Analog outputs and RS-232 output against display	√	√	
Replace the oxygen sensor			√ Sensor life expectancy 3-4 years

Figure 20 –Maintenance schedule

4.3 Troubleshooting

4.3.1 Fault Codes

When trouble occurs during normal operation of the Model 7100E, the user has several tools available to aid in isolating the cause(s) of given symptoms. As a starting point, the user may use the control panel to enter into “View Active Faults” mode (section 3.2.4). The user may also view active faults and other useful information via the Service Port (section 4.1.2). In addition, there are four system Hot-Keys available to perform special functions, and to gather important information quickly and easily (Appendix-D). Descriptions of faults are given below, with indication of common causes. Refer to the appropriate sections of this manual for more details as needed

4.3.1.1 Fault Code 1 – Oven or Sensor warming up

The “Oven or Sensor warming up” fault indicates that the oxygen sensor is being heated to its operating temperature after a fresh power up. The purpose of the alarm is to provide a control output to indicate that the sensor has not yet reached its operating temperature, and the model 7100E is not yet ready for in-service oxygen measurement.

4.3.1.2 Fault Code 2 – Relays are in Standby mode

The “Relays are in Standby mode” fault indicates that the user has aborted the control panel user mode menu properly (section 3.2.5), and the unit is in a stabilization period to allow time to sweep the sample lines with sample gas before returning the unit to on-line service. During the stabilization period, Alarm-1, Alarm-2 and Fault relays remain inactive, and held to their last state before the control panel user mode menu was accessed. The factory default setting for this period is 120-seconds. This setting is user-configurable (section 4.1.2.10.8).

4.3.1.3 Fault Code 3 – Device is in Setup mode – Service Port

The “Device is in Setup mode” fault indicates that the user has entered the user setup mode from the service port (section 4.1.2), and the model 7100E is not monitoring oxygen in the process. The 7-segment alphanumeric display will show “SU”. The Device is in Setup Mode fault will clear when the user returns the unit to Run mode.

4.3.1.4 Fault Code 5 – Analog Output range overflow

The “Analog Output range overflow” fault indicates an oxygen reading that is above the range configuration entered in the model 7100E setup (section 4.1.2.12). Possible causes of fault code-5 may be: Incorrect or contaminated calibration gases, faulty process or calibration sampling lines/components.

4.3.1.5 Fault Code 6 – Analog Output range underflow

The “Analog Output range overflow” fault indicates an oxygen reading that is below the range configuration entered in the model 7100E setup (section 4.1.2.12). Possible causes of fault code-6 may be: Analog Range lower limit set to a value greater than zero (section 4.1.2.11.1).

4.3.1.6 Fault Code 8 – A concentration reading is not yet available

The “concentration reading is not yet available” fault is active when the model 7100E is not ready for online service. It is active during start-up, calibration and during fault code-2 – relays are in standby mode.

4.3.1.7 Fault Code 10 –Sensor appears to be disconnected

The “Sensor appears to be disconnected” fault indicates that there is not a continuous electrical circuit connecting the Model 1100 and the oxygen sensor. Possible causes may be: An open in the sensor interface wiring, faulty connecting hardware on/in the model 7100E or the sensor, the sensor interface cable has been un-plugged.

4.3.1.8 Fault Code 11 – Non-native display range

The “non-native display range” fault indicates an oxygen reading that is above the range configuration entered in the model 7100E setup (section 4.1.2.12). Fault code-11 is active when fault code 5 is active. Possible causes of fault code-11 may be: Incorrect or contaminated calibration gases, faulty process or calibration sampling lines/components.

4.3.1.9 Fault Code 12 – User calibration too large

The “user calibration too large” fault indicates that the reading during calibration was out of tolerance high with respect to the known calibration gas concentration. The calibration tolerance window is factory-set and cannot be changed by the user. Possible causes of fault code-12 may be: Incorrect or contaminated calibration gases, faulty process or calibration sampling lines/components.

4.3.1.10 Fault Code 13 – User calibration too small

The “user calibration too small” fault indicates that the reading during calibration was out of tolerance low with respect to the known calibration gas concentration. The calibration tolerance window is factory-set and cannot be changed by the user. Possible causes of fault code-13 may be: Incorrect or contaminated calibration gases, faulty process or calibration sampling lines/components, faulty or failing sensor.

4.3.1.11 Fault Code 15 – Bad user calibration

The “bad user calibration” fault indicates that the user has attempted to calibrate the model 7100E with what appears to be a faulty sensor. Possible causes of fault code 15 are: Incorrect or contaminated calibration gases, improper calibration procedure, faulty sensor.

5

CHAPTER 5 – APPENDICES

5.1 Appendix A – Spare Parts List

PART NUMBER	DESCRIPTION
5-06-4900-14-1	Operations Manual
C1-11-1220-03-0	VAC Fuses for Power Supply Board (for VAC units only). – 1 A, 250 VAC, Slo-Blo
C1-17-0052-00-0	Replacement terminal block – TB1
C1-17-0142-00-0	Replacement terminal block – TB2
C1-17-0112-00-0	Replacement terminal block – TB3

5.2 Appendix B – Specifications

OXYGEN SENSOR	External Compact Zirconium Oxide								
DISPLAY	<p>0.75" 7-segment LED digital display, 4 characters Displays oxygen from 0 to 2000 parts-per-million.</p> <p>Resolution:</p> <table> <tr> <td>0–9.9 PPM</td> <td>X.X</td> </tr> <tr> <td>10–99 PPM</td> <td>XX.</td> </tr> <tr> <td>100–999 PPM</td> <td>XXX.</td> </tr> <tr> <td>1,000-2,000 PPM</td> <td>XXXX.</td> </tr> </table> <p>Color -Coded LED's for system status:</p> <p>RUN: Green FAULT: Yellow ALARM-1: Red ALARM-2: Red</p>	0–9.9 PPM	X.X	10–99 PPM	XX.	100–999 PPM	XXX.	1,000-2,000 PPM	XXXX.
0–9.9 PPM	X.X								
10–99 PPM	XX.								
100–999 PPM	XXX.								
1,000-2,000 PPM	XXXX.								
SIGNAL INTERFACE	<p>Serial Service Port: Bi-directional RS-232</p> <p>Analog Voltage Output: 0–1, 0–5, or 0–10 VDC</p> <p>Analog Current Output: Non-isolated 4 – 20 mA, 12 VDC, negative ground, powered by analyzer, maximum electrical load 250 Ohms</p> <p>Range ID Voltage:</p> <table> <tr> <td>0–10 PPM</td> <td>3.13 VDC ± 0.1VDC</td> </tr> <tr> <td>0–100PM</td> <td>3.75 VDC ± 0.1VDC</td> </tr> <tr> <td>0–1,000 PPM</td> <td>4.38 VDC ± 0.1VDC</td> </tr> <tr> <td>0–2,000 PPM</td> <td>5.00 VDC ± 0.1VDC</td> </tr> </table>	0–10 PPM	3.13 VDC ± 0.1VDC	0–100PM	3.75 VDC ± 0.1VDC	0–1,000 PPM	4.38 VDC ± 0.1VDC	0–2,000 PPM	5.00 VDC ± 0.1VDC
0–10 PPM	3.13 VDC ± 0.1VDC								
0–100PM	3.75 VDC ± 0.1VDC								
0–1,000 PPM	4.38 VDC ± 0.1VDC								
0–2,000 PPM	5.00 VDC ± 0.1VDC								
RELAY OUTPUTS	<p>Alarm-1: Field Adjustable Form C (SPDT) Voltage-free, 5A @ 250 VAC, 5A @ 30 VDC. Configurable to fail-safe/non fail-safe and ascending/descending action</p> <p>Alarm-2: Field Adjustable Form C (SPDT) Voltage-free, 5A @ 250 VAC, 5A @ 30 VDC. Configurable to fail-safe/non fail-safe and ascending/descending action</p> <p>Fault: Non-adjustable Form B (SPST) Voltage-free, 5A @ 250 VAC, 5A @ 30 VDC, non Fail Safe action, non-configurable.</p>								

Specifications are subject to change without notice.

Appendix B - Specifications

RANGE	0-10 PPM • 0-100 PPM • 0-1000 PPM • 0-2000 PPM
ACCURACY	± 1.5 % of range @ calibrated temperature and pressure
RESPONSE TIME	T ₉₀ < 5 seconds
WARM UP TIME	60-seconds
HUMIDITY	Analyzer: 0-95 % non-condensing Sensor: 0-90 % non-condensing
OPERATING TEMPERATURE	Analyzer: 32-122° F (0-50° C) Sensor: 14-167° F (-10-75° C)
STORAGE TEMPERATURE	Analyzer: 23-122° F (-5-50° C) Sensor: 14-185° F (-10-85° C)
SAMPLE PRESSURE	15" Hg vacuum-7 PSIG (0.5-1.5 Bar)
SAMPLE FLOW	0.5-1.5 LPM (1 LPM nominal)
POWER	VAC Unit: 90 – 264 VAC, 47 – 63 Hz, Single Phase, 13 Watts VDC Unit: 11 – 18 VDC, 13 Watts 20 – 30 VDC, 13 Watts
MECHANICAL	Faceplate: Height 3.75" x Width 7.00" • NEMA 4 • IP66 Panel Cut-out: Height 2.91" x Width 6.20" Electronic Compartment: Height 2.81" x Width 5.98" x 3.60" Depth • NEMA 1 • IP20
WEIGHT	3 Lbs (1.4 kg)
WARRANTY	12-months from date of shipment

Specifications are subject to change without notice.

Appendices

5.3 APPENDIX C – ANALYZER FACTORY CONFIGURATION SETTINGS

Alarm and Relay Setup Information

Alarm-1/Alarm-2 Relays Failsafe/Non-Failsafe	NON-FAILSAFE
Alarm-1/Alarm-2 Relay Ascending/Descending	ASCENDING
Alarm-1 Trigger Level	50 PPM
Alarm-2 Trigger Level	100 PPM

Display Range

0–10 PPM Fixed	
0–100 PPM Fixed	
0–1,000 PPM Fixed	
0–2,000 PPM Fixed	
Auto Ranging	

Analog Voltage Output

0–1 VDC	X
0–5 VDC	
0–10 VDC	

Rs-232 Baud Rate

300 BPS	
1200 BPS	
2400 BPS	
4800 BPS	
9600 BPS	X
19200 BPS	
38400 BPS	

Relay Disable after Cal/Setup

120-seconds	X
-------------	---

Assume Low End Calibration Range

Single Point Calibration	
0–5 PPM	
10–50 PPM	X
10–500 PPM	

Rs-232 Timed Output Format (Select One)

Output on Request Only	
Human Readable Format	X
Machine Code	
Machine Code With Checksum	
Tab Delimited (Spreadsheet)	

Supply Voltage

90 – 264 VAC, 47 – 63 Hz	X
11 – 18 VDC	
20 – 30 VDC	

RS-232 Dump Rate

1-second	X
----------	---

5.4 APPENDIX D – Control panel Hot-Key Functions

For convenience in operating and troubleshooting, the Model 1100 has four Control panel Hot-Key functions that can be performed quickly via the control panel without entering the normal Control panel, or Service Port user menus.

KEYS PRESSED	DESCRIPTION OF FUNCTION
UP + DOWN	Return to “RUN” mode from any User mode
UP + DOWN (hold both keys for 10 seconds *)	Run Lamp Test
DOWN then MODE (hold both keys for 10 seconds *)	Show Sensor Voltage
UP then MODE (hold both keys for 10 seconds *)	Re-start Model 1100

* Hold all keys indicated until the 7-segment alphanumeric display shows “---“ then release the pressed keys. To return to normal operation, press and release the same keys again.

5.5 APPENDIX E – Range / Output Chart

RANGE NAME	MEASURED RANGE	DISPLAY	ANALOG RANGE	RANGE ID VOLTAGE OUTPUT
AUTO RANGE	0.1–9.9 PPM 10–99 PPM 100–999 PPM 1000–2000 PPM	X.X XX. XXX. XXXX.	0–10 PPM 0–100 PPM 0–1,000 PPM 0–2000 PPM	3.13 VDC 3.75 VDC 4.38 VDC 5.00 VDC
FIXED RANGE 10 PPM	0-9.9 PPM	X.X	0–10 PPM	3.13 VDC
FIXED RANGE 100 PPM	0-99 PPM	XX.	0–100 PPM	3.75 VDC
FIXED RANGE 1000 PPM	0-999 PPM	XXX.	0–1,000 PPM	4.38 VDC
FIXED RANGE 2,000 PPM	0-2000 PPM	XXXX.	0–2,000 PPM	5.00 VDC

5.6 APPENDIX F – Zero Calibration Range Settings

ENTERED VALUE	RANGE	AVAILABLE SETTINGS
0	Single Point Calibration	
1	1 PPB – 50 PPB	
2	1 PPB – 500 PPB	
3	1 PPM – 5 PPM	
4	10 PPM – 50 PPM	X
5	10 PPM – 500 PPM	X
6	0.0 % – 0.5 %	
7	1 % – 5 %	
8	1 % – 50 %	
9	18 % - 24 %	
10	10 PPM – 20 PPM	

5.7 APPENDIX G – MSDS Material Safety Data Sheet

1. Product Identification

Oxygen sensor solid state type, model ZR-200, furnished by Neutronics Inc. • 456 Creamery Way • Exton, PA USA, 19341 • Telephone: 610-524-8800.

2. Hazardous Ingredients of Solution

None

3. Health Hazard

None

4. Physical and Chemical Data

Yttrium stabilized Zirconia element with platinum electrodes and heater element. No information available. Contact Neutronics Inc for more information if needed.

5. Unusual Fire and Explosion Hazards

None

6. Health Hazard Data

No hazards are encountered during normal operation. Do not touch heated cell. Allow unit to cool down before servicing.

7. Emergency and First-Aid Procedures

Skin Contact with hot sensor: Immediately flush skin with plenty of water for 15 minutes.

8. Handling

Protective measures during cell replacement:

Do not remove sensor from analyzer while the instrument is powered or while the sensor is still hot.

Note: The above data is based on MSDS provided by the manufacturers of components and by tests conducted by Neutronics. Neutronics believes that this information to be accurate and reliable. This information is supplied as reference only. Neutronics disclaims any liability for damage or injury which results from the use of the data and nothing contained therein shall constitute a guarantee, warranty, or merchantability or representation by Neutronics with respect to the data, the product described, or their use for any specific purpose, even if that purpose is known to Neutronics.

5.8 APPENDIX H – Warranty

Neutronics warrants to the original purchaser, that the Model 7100E Oxygen analyzer is free from defects in material and workmanship for a period of one (1) year from the date of shipment from Neutronics or from one of Neutronics' authorized dealers. Our liability will be limited to the repair or replacement, at our factory, of parts found to be defective within the warranty period, as determined by Neutronics. The parts will be repaired or replaced free of charge if shipped prepaid to the factory in the original shipping carton. This warranty is void if the product has been subject to misuse or abuse, including but not limited to: exposure to water, humidity, temperature, shock or pressure outside of the listed specifications, or has not been operated or installed in accordance with operating and maintenance instructions, for repairs which were not performed by Neutronics or by one of its authorized dealers, or if the identifying markings on the product label have been altered or removed.

The seller assumes no liability for consequential damages of any kind, and the buyer, by acceptance through purchase of this product, will assume all liability for the consequences of its use or misuse by the buyer, his employees, or others.

Neutronics reserves the right to use any materials in the manufacture, repair or service of the products and to modify the design as deemed suitable, in so far as these materials or modifications maintain the stated warranty.

It is the sole responsibility of the buyer / user to determine if this product is suitable for the intended application.

THESE WARRANTIES ARE EXCLUSIVE AND IN LIEU OF ALL OTHER WARRANTIES, EXPRESSED, OR IMPLIED INCLUDING WARRANTY OF MERCHANTABILITY, FITNESS FOR A PARTICULAR PURPOSE.

Intended Use for the Model 7100E

The model 7100E Oxygen analyzer was designed to provide the trained operator with useful information relating to the concentration of Oxygen. This information may be used in process control or to minimize possible hazardous conditions, which may be present in various processes. Before implementation, the user must fully understand the operation and limitations of this instrument as well as the application for its use. The responsibility for the proper application, operation, installation, and maintenance of the model 7100E Oxygen analyzer is the sole obligation of the trained operator. The purchaser is required to ensure operators are properly trained in the use of this unit as well as in the possible hazards associated with its use or with the intended application. The purchaser must ensure that all of the proper warnings, labels, instruction manuals, lock outs, redundant components, hazard analysis, and system validation have been completed and provided to the trained operator before implementation of the model 7100E instrument.