

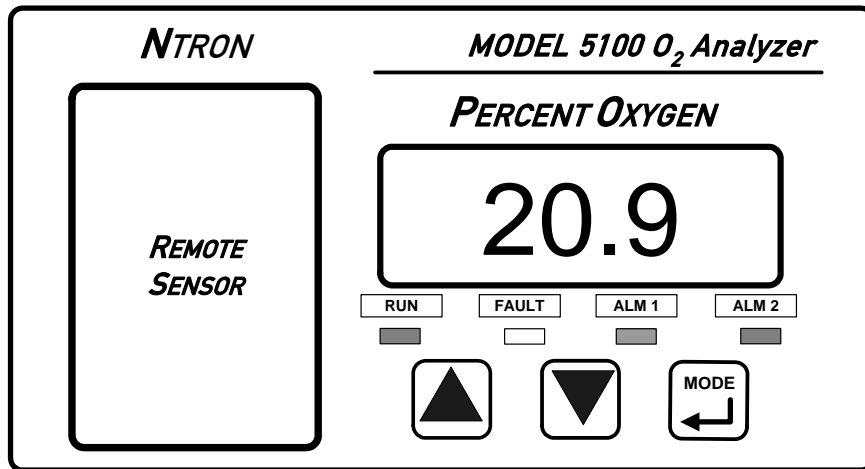

High Purity Instruments

MODEL 5100E

OXYGEN ANALYZER / CONTROLLER – PERCENT RANGE OPERATIONS MANUAL



File Name: MN-A-0008
Manual Part Number: C5-06-4900-08-0
Revision Level: C Revision Date: 11/27/06
ECO: 8029



456 Creamery Way, Exton, PA 19341
Phone: 610.524.8800 • Fax: 610.524.8807 • Email: info@neutronicsinc.com
www.neutronicsinc.com

Table of Contents

TABLE OF CONTENTS III

FOR YOUR SAFETY: V

WELCOME VI

CHAPTER 1 – INTRODUCTION AND OVERVIEW 1-1

1.1 GENERAL 1-1

1.2 FEATURES 1-1

1.3 SYSTEM HARDWARE OVERVIEW 1-3

 1.3.1 *Main Board*..... 1-3

 1.3.2 *Relay Board* 1-3

 1.3.3 *Power Supply* 1-3

 1.3.4 *Display Board*..... 1-3

 1.3.5 *Control Panel* 1-3

 1.3.6 *Sensor* 1-4

 1.3.7 *Sensor Flow-Through Head*..... 1-4

 1.3.8 *Chassis*..... 1-5

1.4 ANALYZER INPUTS AND OUTPUTS 1-7

 1.4.1 *The Oxygen Sensor Input* 1-7

 1.4.2 *Alarm-1 Relay Output*..... 1-7

 1.4.3 *Alarm-2 Relay Output*..... 1-7

 1.4.4 *Fault Relay Output*..... 1-7

 1.4.5 *Warm-up Relay Output* 1-7

 1.4.6 *Analog Voltage Output*..... 1-7

 1.4.7 *Analog Current Output* 1-8

 1.4.8 *Range ID Output*..... 1-8

 1.4.9 *Service Port*..... 1-8

1.5 CONTROL PANEL USER INTERFACE 1-8

 1.5.1 *The “UP” Pushbutton*..... 1-8

 1.5.2 *The “DOWN” Pushbutton* 1-8

 1.5.3 *The “MODE” Pushbutton* 1-8

 1.5.4 *7-Segment Alphanumeric Display* 1-9

 1.5.5 *RUN Indicator LED*..... 1-9

 1.5.6 *Alarm-1 Indicator LED*..... 1-9

 1.5.7 *Alarm-2 Indicator LED*..... 1-9

 1.5.8 *Fault Indicator LED*..... 1-9

CHAPTER 2 – SYSTEM INSTALLATION AND START-UP 2-1

2.1 INSTALLING THE ANALYZER..... 2-1

 2.1.1 *Step 1 – Locate and Mount the Analyzer Unit* 2-2

 2.1.2 *Step 2 –Install the Remote Sensor* 2-3

 2.1.3 *Step 3 –Electrical Installation* 2-5

2.2 STARTING UP AND COMMISSIONING THE SYSTEM 2-11

 2.2.1 *STEP 1 – Power Up the unit* 2-11

 2.2.2 *STEP 2 – Calibrate the Unit*..... 2-12

 2.2.3 *STEP 3 –Set Alarm-1 and Alarm-2*..... 2-12

CHAPTER 3 – ANALYZER OPERATION 3-1

- 3.1 SYSTEM ORGANIZATION..... 3-1
- 3.2 USER MODES 3-1
 - 3.2.1 CALIBRATE Mode & Calibration Procedure..... 3-1
 - 3.2.2 SET/VIEW ALARM-1 Mode 3-3
 - 3.2.3 SET/VIEW ALARM-2 Mode 3-4
 - 3.2.4 VIEW ACTIVE FAULTS Mode 3-4
 - 3.2.5 Return to RUN Mode..... 3-4
- 3.3 SYSTEM MODES 3-4
 - 3.3.1 Self-Test & Warm-up Mode 3-4
 - 3.3.2 RUN Mode 3-4
 - 3.3.3 ALARM-1 ACTIVE Mode..... 3-5
 - 3.3.4 ALARM-2 ACTIVE Mode..... 3-5
 - 3.3.5 FAULT ACTIVE Mode..... 3-5
- CHAPTER 4 – MAINTENANCE AND TROUBLESHOOTING..... 4-1**
 - 4.1 SYSTEM SETUP 4-1
 - 4.1.1 System Setup via Control panel Keypad 4-1
 - 4.1.2 System Setup via Service Port 4-3
 - 4.1.3 Change factory settings via Hardware Jumpers 4-14
 - 4.2 ROUTINE PERIODIC MAINTENANCE..... 4-16
 - 4.3 TROUBLESHOOTING 4-17
 - 4.3.1 Fault Codes 4-17
- CHAPTER 5 – APPENDICES..... 5-1**
 - 5.1 APPENDIX A – SPARE PARTS LIST..... 5-1
 - 5.2 APPENDIX B - SPECIFICATIONS..... 5-2
 - 5.3 APPENDIX C – ANALYZER FACTORY CONFIGURATION SETTINGS..... 5-4
 - 5.4 APPENDIX D – CONTROL PANEL HOT-KEY FUNCTIONS..... 5-5
 - 5.5 APPENDIX E – RANGE / OUTPUT CHART..... 5-6
 - 5.6 APPENDIX F – MSDS MATERIAL SAFETY DATA SHEET..... 5-7
 - 5.7 APPENDIX G – WARRANTY 5-8
- INTENDED USE FOR THE MODEL 5100E..... 5-8**



For Your Safety:

PLEASE READ THIS MANUAL IN ITS ENTIRETY BEFORE ATTEMPTING INSTALLATION OR OPERATION! Attempting to operate the Model 5100E without fully understanding its features and functions may result in unsafe conditions.

- Always use protective eye wear and observe proper safety procedures when working with pressurized gases.
- Always assure the pressure of gas entering the Model 5100E sensor is 1-10 psig. Not to exceed 20 psig
- Always calibrate the Model 5100E at an equivalent pressure and flow rate to the measured gas. Maximum pressure should not exceed 10 psig.
- Always allow the Model 5100E to cool down before attempting to access the sensor.
- Ensure the Model 5100E has been properly calibrated before use.
- Never expose the Model 5100E analyzer chassis to water, high humidity or moisture. The analyzer chassis is not watertight.
- Never expose the Model 5100E to flame or high temperatures.
- Never expose the Model 5100E analyzer to flammable gases or vapors. The unit is not rated Explosion Proof, or Intrinsically Safe.
- Never expose the Model 5100E directly to unregulated gas lines, cylinder gas. High gas pressures may cause the sensor components to rupture.
- Ensure the analyzer unit is mounted in an area of free airflow to prevent the chassis from exceeding the operating temperature specifications. Do not mount the analyzer against hot surfaces. Do not block the ventilation louver on the analyzer chassis.

WELCOME

Thank you for purchasing the Model 5100E Analyzer for zero to 100 % range Oxygen measurement.

The Model 5100E Compact Analyzer is a user friendly, microprocessor controlled Oxygen measuring instrument. It has many features to offer the user, which will be described in this manual. We require that all personnel who use the instrument read this manual to become more familiar with its proper operation.

For further detail regarding the maintenance and in-field service of the Model 5100E analyzer, please contact the Neutronics Inc. Customer Service Department. If you have questions or comments, we would like to hear from you.

Neutronics Inc. Customer Service Department
456 Creamery Way
Exton, PA 19341
Tel: (610) 524-8800
Toll Free: (800) 378-2287 (US only)
Fax: (610) 524-8807

EMAIL: info@neutronicsinc.com
Visit us at www.neutronicsinc.com

Equipment Serial Number: _____

(For faster service, please have this number ready if for any reason you need to contact us about your instrument)

Copyright ©2006 Neutronics Inc.

This work is protected under Title 17 of the US Code and is the sole property of Neutronics Inc. No part of this document may be copied or otherwise reproduced, or stored in any electronic information retrieval system, except as specifically permitted under US copyright law, without the prior written consent of Neutronics Inc.

1

CHAPTER 1 – INTRODUCTION AND OVERVIEW

1.1 General

The Model 5100E *Compact Series* analyzer by Neutronics offers an efficient solution in a small package for oxygen measurement and control applications. The Model 5100E is a microprocessor-based instrument for measuring zero to 100 % oxygen.

At the heart of the analyzer is the Model ZR-500E rapid-response Zirconium Oxide oxygen sensor. This sensor assures reliability and fast response for critical measurements from zero to 100 %. It utilizes a unique solid-state sensor, which offers long life with little periodic maintenance. It is unaffected by dry atmospheres, is undamaged by extremely cold storage temperatures, and has indefinite storage life.

The ZR-500E sensor is remote mounted to allow the sensor to be installed close to a sampling point for the fastest response time possible in process monitoring and control applications. A flow-through mounting head is supplied for use with all Neutronics Inc. process gas sampling systems. Neutronics also provides a wide variety of built-to-application, and custom process sampling systems.

1.2 Features

The *Compact Series* analyzers are designed to be flush mounted to a panel or console. Because of the small size of the Model 5100E analyzer, it can be integrated into a variety of equipment or control panels. The Remote Sensor Module should be mounted as close as possible to the sampling point.

Other Features Include:

- Compact, rapid-response Zirconia oxygen sensor
- Two User-adjustable oxygen Alarms with configurable relay outputs for process control use
- Two Analog Outputs: 4-20 mA AND 0-1, 0-5, or 0-10 VDC
- Auto Ranging or Fixed Range Oxygen Measurement (VDC output provided for auto-range identification)
- Bi-directional RS-232 Serial Interface for connection to a PC, terminal, or printer

Model 5100E – Introduction and Overview

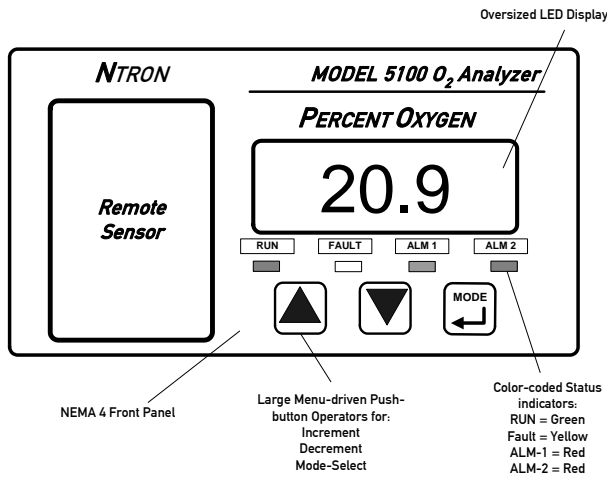

Front view

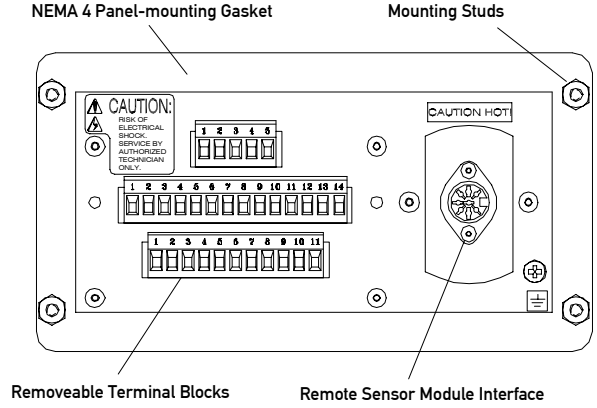

Rear view

Figure 1 – Model 5100E oxygen analyzer front and rear view

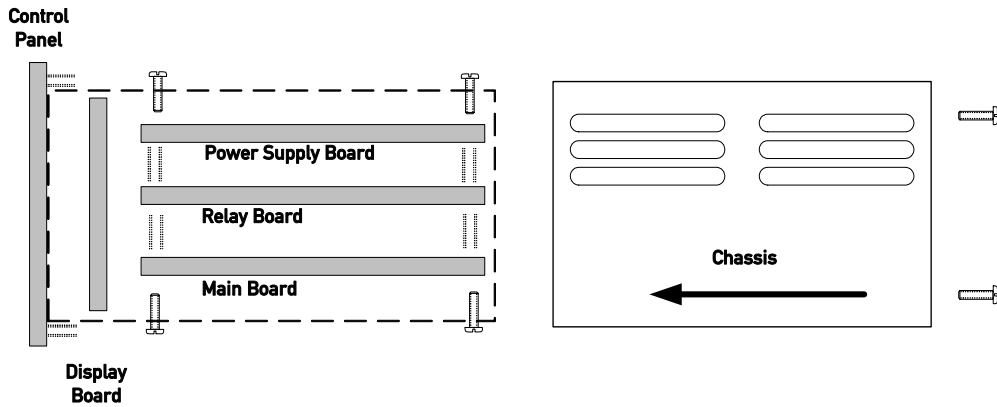

Figure 2 – Basic internal analyzer components

1.3 System Hardware Overview

1.3.1 Main Board

The main board houses the microprocessor, and supporting electronics for controlling the operation of the Model 5100E Analyzer. The main board receives the sensor input, and provides the control and display functions of the analyzer.

1.3.2 Relay Board

The Relay Board houses relay contacts for all of the Alarm and Control features of the 5100E. The relays are mapped discretely to each alarm to provide electrical outputs for reporting, and process control use.

1.3.3 Power Supply

The power supply board is designed to take 110/220 VAC, 50/60 Hz mains power input. The supply is fused directly on the board. Optional 24 VDC power supply is available for installations where a DC voltage is required to power the Model 5100E. A 12 VDC battery-backup power input (battery not provided) is also provided to act as an emergency back up in case of mains power failure.

1.3.4 Display Board

The Display board is designed to generate a digital indication of the concentration of oxygen (Appendix E – range / output chart), and fault codes (section 4.3.1). The display is a 7-segment, $\frac{3}{4}$ " alphanumeric LED.

1.3.5 Control Panel

The Control Panel serves as the main user interface. The Control Panel features the keypad (ramp-UP, ramp-DOWN, and MODE keys) and the status LED's. The control panel is designed to be splash and water-resistant. There are #8-32 threaded mounting studs at each of the four corners for flush mounting of the Model 5100E to a control or equipment panel. The gasketed panel is suitable for NEMA type 4 / IP20 environments when properly installed.

Model 5100E – Introduction and Overview

1.3.6 Sensor

The Neutronics Inc ZR-500E mini Zirconia sensor for measuring percent range oxygen is a cost effective solution for many applications. It is a solid-state device based on a Zirconia solid electrolyte sensor with a low power, on-board heater, and two electrodes. Unlike many solid-state oxygen sensors, the ZR-500E does not require a reference gas for normal operation (see calibration requirements).

The sensor is mounted directly onto a printed circuit board that supplies bias and heater voltages to the sensor element. A small capillary on the sensor surface controls diffusion of oxygen into the sensor. At operational temperature, oxygen is electrochemically reduced, causing current flow through the solid electrolyte. Oxygen concentration in the sample gas is determined by measuring the current flowing through the sensor's two electrodes.

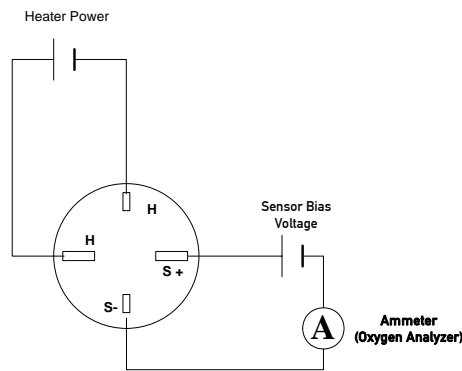

Figure 3 –ZR-500E sensor circuit

The robust design of the ZR-500E sensor assures accurate measurement as well as a quick response characteristic to serve a wide range of oxygen measurement applications. Its expected operating life is 2 years under normal operating conditions, and it has an unlimited shelf life. It is not affected by position, and it may be exposed to high atmospheric pressures with no ill effect on performance.

1.3.7 Sensor Flow-Through Head

The sensor mounting-base allows the Model ZR-500E sensor to be used for process monitoring. It serves as both the receptacle for the sensor and the delivery system for a gas sample from a process vessel or stream. It includes a sample inlet, a flow-through chamber a sample exhaust, and a screw-in receptacle for the oxygen sensor.

1.3.7.1 Sample Gas Inlet

A sample gas inlet port is provided for installation with a process oxygen sampling system. Gas must be directed from the measured process to the sample inlet port via positive pressure from the source, or an external pump. The Model ZR-500E sensor and flow-through head combination can be installed in any Neutronics Inc. Process Sampling System.

1.3.7.2 Sample Gas Exhaust

A sample gas exhaust port is provided for installation with a process oxygen sampling system. Gas must be directed from the sample exhaust port to an exhaust at ambient pressure. Any change in pressure to the exhaust port of the analyzer will affect its reading and accuracy.

**Figure 4 –
Sensor flow-
through head**

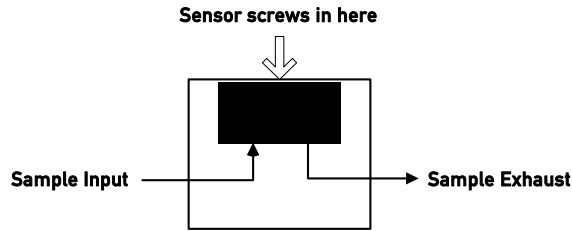

1.3.8 Chassis

The chassis is manufactured from stainless steel. It is designed to provide a general level of protection against mechanical damage from the local environment. It is also an important component of the electrostatic discharge (ESD) shielding design. Since the Model 5100E is a flush mounted system, the portion of the instrument housed in the chassis will be located behind the control panel or embedded within the customer equipment enclosure. The enclosure is general purpose and is not watertight.

**Figure 5 –
Analyzer chassis**

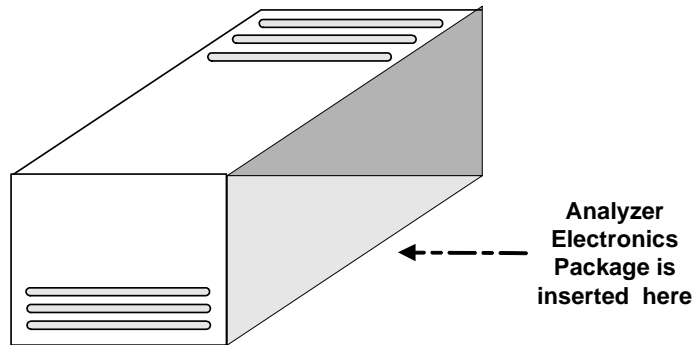

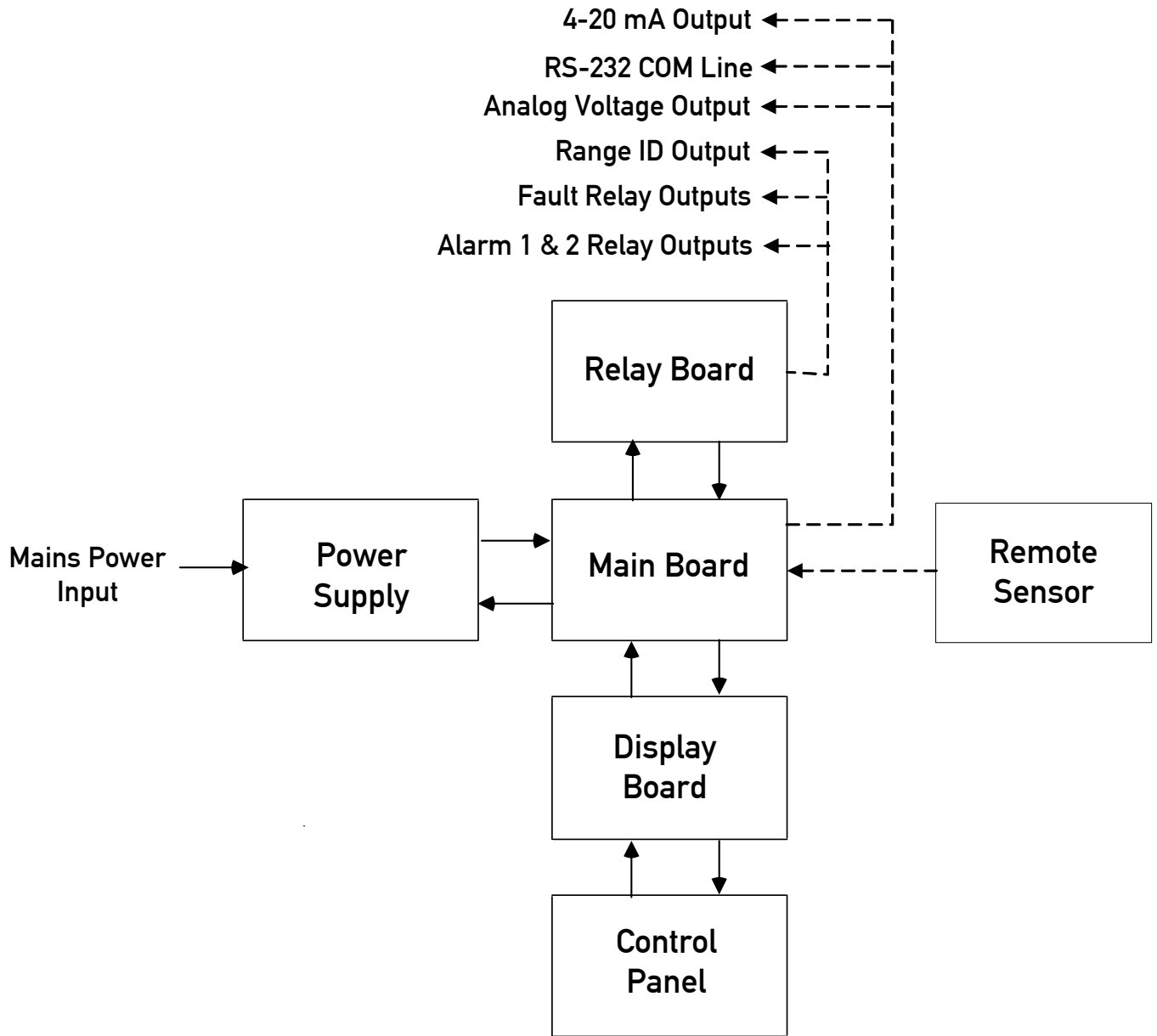

Figure 6 – Analyzer system configuration

1.4 Analyzer Inputs and Outputs

1.4.1 The Oxygen Sensor Input

The oxygen sensor electrical input to the Model 5100E is used to indicate the oxygen concentration measured by the Model ZR-500E oxygen sensor. It is proportional to the oxygen present in the measured gas at the sensor membrane. The oxygen sensor input is a female 7-pin DIN connector to mate with the supplied sensor interface cable connector.

1.4.2 Alarm-1 Relay Output

The Alarm-1 relay is mapped to the Alarm-1 setpoint, and is provided for process control use. The user may set the oxygen level at which Alarm-1 activates (section 3.2.2). Alarm-1 may be configured as ascending (highest oxygen level allowable) or descending (lowest oxygen level allowable) action. The relay output may be configured for failsafe (relay coil de-energized in alarm state) or non failsafe (relay coil energized in alarm state) action. Factory default settings are ascending, and non failsafe. The Alarm-1 relay contacts are form 1 C (SPDT), voltage-free.

1.4.3 Alarm-2 Relay Output

The Alarm-2 relay is mapped to the Alarm-2 setpoint, and is provided for process control use. The user may set the oxygen level at which Alarm-2 activates (section 3.2.3). Alarm-2 may be configured as ascending (highest oxygen level allowable) or descending (lowest oxygen level allowable) action. The relay output may be configured for failsafe (relay coil de-energized in alarm state) or non failsafe (relay coil energized in alarm state) action. Factory default settings are ascending, and non failsafe. The Alarm-2 relay contacts are form 1 C (SPDT), voltage-free.

1.4.4 Fault Relay Output

The Fault relay output is used to indicate that there is at least one system fault active on the Model 5100E analyzer (section 4.3.1 – fault codes and definitions). The relay is configured for contact closure with applied power. The contacts will remain closed provided no faults occur. The Fault relay contacts are Form 1 B (SPST), voltage-free. During normal operation the contact is closed.

1.4.5 Warm-up Relay Output

The warm-up relay (listed as temp relay), is located at TB2, pins 1 and 2. This is a failsafe relay; during warm-up the relay will open. Once the temperature of the sensor has stabilized, the contact will close. Approximate time for contact closure is 60 seconds.

1.4.6 Analog Voltage Output

The Analog Voltage output is a dynamic potential used to indicate to a remote device the displayed oxygen concentration during normal analyzer operation and system maintenance. The Analog voltage output follows the oxygen readout displayed on the 7-segment LED display during all system and user modes except for user setup. For a complete listing of available output levels by analyzer range, refer to Appendix E – range / output chart.

The user can set the Analog voltage scale (section 4.1 – system setup). Available settings are 0-1VDC, 0-5VDC, or 0-10VDC. The factory default setting is 0-1 VDC. The Analog voltage output is scaled according to the analyzer's selected range, and must be used in conjunction with the Range ID voltage when the Analyzer is configured for auto-ranging (section 1.4.9).

Model 5100E – Introduction and Overview

1.4.7 Analog Current Output

The Analog Current output is a dynamic current flow used to indicate to a remote device the displayed oxygen concentration during normal analyzer operation and system maintenance. The Analog Current output follows the oxygen readout displayed on the 7-segment LED display during all system and user modes except for user setup. For a complete listing of output levels by analyzer range, refer to Appendix E – range / output chart.

The analog current output may be set to either 0-20 mA or 4-20 mA. Full-scale is fixed at 20 mA. The Analog current output is scaled according to the analyzer's selected range, and may be used in conjunction with the Range ID voltage when the Analyzer is configured for auto-ranging (section 1.4.9).

1.4.8 Range ID Output

The Model 5100E can be configured by the user to automatically switch its measurement range, based on the concentration of oxygen measured while in-service, to provide the most accurate, and highest resolution outputs at all times. For a complete listing of analyzer ranges, refer to Appendix E – range / output chart.

Remote auxiliary devices designed to interpret the Model 5100E Analog outputs over multiple output range scales require an indication of the analyzer's selected range at all times for accurate scaling. The Model 5100E features a 0-10 volt Auto-Range Identification output. The range ID output is used in conjunction with the Analog voltage and Analog current outputs when auto-ranging is used. It provides an indication of the Analog outputs' selected full-scale. There are five range ID voltage levels used in the 5100E to correspond with its five output ranges (Appendix E – range / output chart).

1.4.9 Service Port

The Service port provides a user-friendly means of digital communications with the Model 5100E Analyzer. Through this port, the unit may be configured, calibrated, and queried for most functions. The RS-232 port may also be programmed to send out information on a timed basis for users who prefer to use Digital instead of Analog interfacing with the analyzer. In addition, the service port may be used with a PC based computer (such as a portable notebook computer) over a standard bi-directional RS-232 serial interface.

1.5 Control panel User Interface

1.5.1 The “UP” Pushbutton

The “UP” pushbutton can be used to program the Model 5100E via the control panel. This momentary push-button soft key is used to enter incremental information. Its function is menu-driven.

1.5.2 The “DOWN” Pushbutton

The “DOWN” pushbutton can be used to program the Model 5100E via the control panel. This momentary push-button soft key is used to enter decremental information. Its function is menu-driven.

1.5.3 The “MODE” Pushbutton

The “MODE” pushbutton can be used to program the Model 5100E via the control panel. This momentary push-button soft key is used to navigate the operational modes available through the control panel. Its function is menu-driven.

1.5.4 7-Segment Alphanumeric Display

The 7-Segment alphanumeric display feeds back information from the Model 5100E to the user via the control panel. The primary purpose of the 7-Segment display is to show the oxygen concentration readout. It is also used for feedback of operational status, fault codes, and other information necessary to perform system setup and maintenance.

1.5.5 RUN Indicator LED

The purpose of the RUN Indicator LED is to inform the user via the control panel that the Model 5100E is measuring the concentration of the sample gas and updating the display.

1.5.6 Alarm-1 Indicator LED

The purpose of the Alarm-1 Indicator LED is to inform the user via the control panel that the measured oxygen concentration has exceeded the alarm-1 threshold; alarm-1 LED and its associated relay are in active mode.

1.5.7 Alarm-2 Indicator LED

The purpose of the Alarm-2 Indicator LED is to inform the user via the control panel that the measured oxygen concentration has exceeded the alarm-2 threshold; alarm-2 LED and its associated relay are in active mode.

1.5.8 Fault Indicator LED

The purpose if the Fault Indicator LED is to inform the user via the control panel that at least one system fault is active. Note that when the fault Indicator LED is active, the fault relay will also be active (open).

2 CHAPTER 2 – SYSTEM INSTALLATION AND START-UP

2.1 Installing the Analyzer

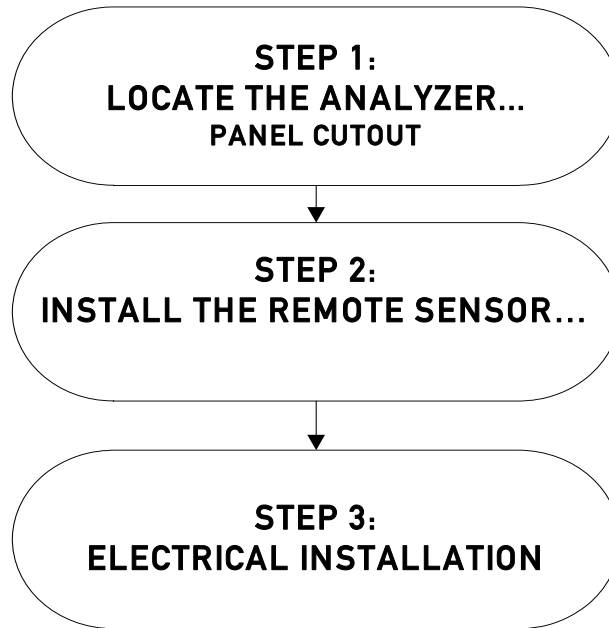

Figure 7 – Installation outline

System Installation and Startup

2.1.1 Step 1 – Locate and Mount the Analyzer Unit

The Model 5100E is designed to be mounted flush to the surface of an equipment control panel. Select a suitable location for the analyzer unit where the digital display and status LED's will be easy to read, and the interface buttons on the display panel will be easy to access.

Cut/drill the mounting panel to the specifications in figure-8. Clearance holes for the #8-32 threaded mounting studs do not need to be tapped. Hex nuts and lock washers are included for securing the unit to a panel. Trim all burrs or sharp edges in the cutout or mounting-holes, which would interfere with or damage the gasket on the analyzer control panel.

Slide the analyzer unit into the cutout, rear-chassis first, and seat the control panel gasket on the mounting surface. The gasket on the analyzer control panel ensures a watertight seal around the control panel cutout. Secure the threaded mounting studs with the supplied hex-nuts, and internal-tooth lock-washers. The analyzer control panel is suitable for NEMA Type 4, IP20 environments when properly installed. The rear electronics chassis is suitable for NEMA Type 1, IP 20 environments.

The analyzer should not be exposed to water, adverse temperature, or shock. Ensure the analyzer unit is mounted in an area of free airflow to prevent the chassis from exceeding the operating temperature specifications. Do not mount the analyzer or sensor against hot surfaces. Do not block the ventilation louver on the analyzer chassis.

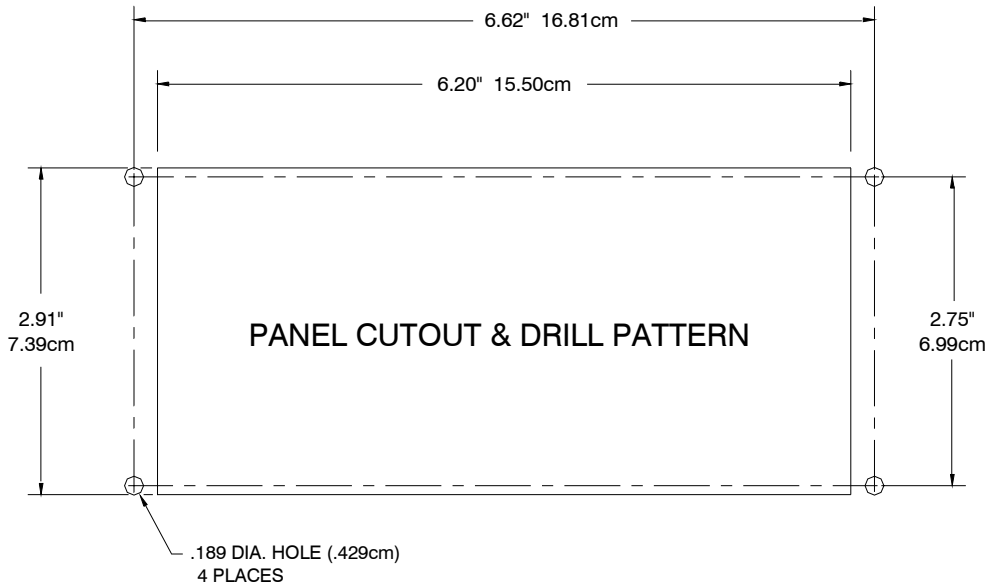

Figure 8 – Analyzer mounting

2.1.2 Step 2 –Install the Remote Sensor

The Model 5100E is supplied with a Model ZR-500E oxygen sensor, and sensor flow-through head for connection to a sampled process gas stream, and a sensor interface cable. The Model 5100E can also be supplied with a Neutronics Inc. process Sampling system, built-to-application. NOTE: For instructions on the installation of a Neutronics Inc. Process Sampling System, please refer to the sampling system equipment manual.

2.1.2.1 Flow-through Head

Surface-mount the flow through head horizontally (as shown in figure 9) or vertically on a stationary panel. The sensor flow-through head is 1.25” diameter stainless steel, and is machined to accommodate two # 6-32 machine-type mounting screws (1-inch on center). Be careful not to over tighten the mounting screws. Allow sufficient space to screw the Model ZR-500E oxygen sensor into the top threaded port of the flow through head, and for the sample lines and sample inlet and exhaust fittings.

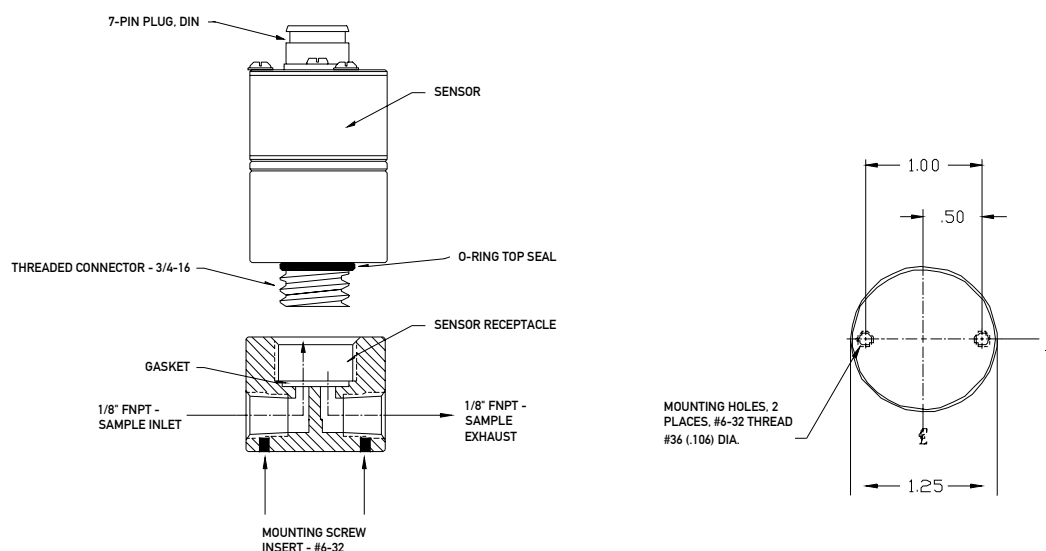

Figure 9 – Sensor mounting detail

2.1.2.2 Sample Inlet Port

Pneumatic connection to the measured process for sample extraction is made at either of the two interchangeable 1/8” FNPT fitting around the side of the flow-through head. For connecting the flow-through head to the measured process, use 1/8” or 1/4” rigid tubing, and 1/8” MNPT fittings of a material compatible with process gas composition. Ensure that no grease, particulate, or solvent is present in the tubing during installation. Use thread-tape to seal connections, and prevent gauling. Fix all sample tubing and connectors.

A fixed calibration port may be implemented in the process sampling line by installing a 1/8” or 1/4” 3-way manual ball valve into the sampling line as in figure-9. Use 1/8” or 1/4” rigid tubing and 1/8” MNPT fittings of a material compatible with process gas composition. Ensure that no grease, particulate, or solvent is present in the tubing during installation. Use thread-tape only to seal connections, and prevent galling. Fix all sample tubing and connectors.

System Installation and Startup

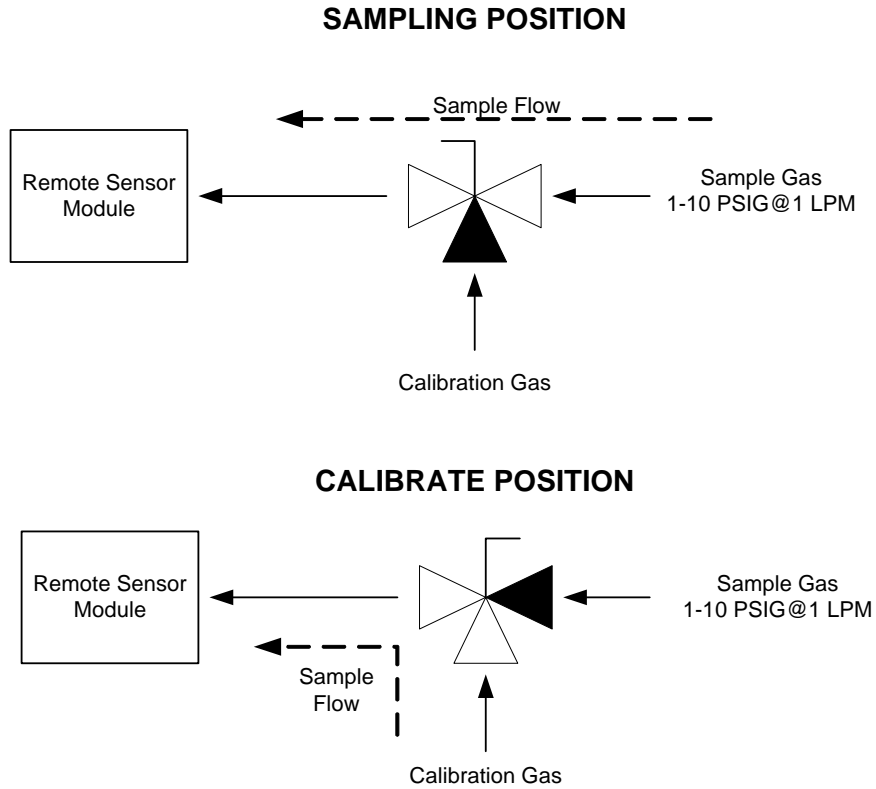

Figure 10 – Calibration gas fixture configuration (typical) – see calibration section (3.2.1) for calibration procedure details.

2.1.2.3 Sample Exhaust Port

Pneumatic connection to a suitable sample stream vent location is made at either of the two interchangeable 1/8" FNPT fitting around the side of the flow-through head, but opposite the installed sample inlet port (section 2.1.2.2). For connecting the sample exhaust to vent, use 1/8" or 1/4" rigid tubing and 1/8" MNPT fittings of a material compatible with process gas composition. Select a vent location that is known to be at atmospheric pressure at all times. Use a minimum 2-meters of tubing to prevent back-flow of vent gas to the sensor. Ensure that no grease, particulate, or solvent is present in the tubing during installation. Use thread-tape only to seal connections, and prevent galling. Fix all sample tubing and connectors.

2.1.2.4 Sensor

The ZR-200 sensor pneumatic connection to the process gas stream is made at the 3/4-16 threaded flow-through head connection with a supplied top seal o-ring and receptacle gasket. Electrical connection to the Model 5100E is made at the female 7-pin DIN connector with a screw-on capture ring.

Connect the sensor to the flow-through head. Verify the supplied o-ring is in place at the base of the sensor, over the 3/4-16 threaded connector. Do not lubricate the o-ring. Verify the supplied gasket is seated in the bottom of the flow-through head sensor receptacle. Screw the sensor into the flow-through head sensor receptacle, and hand-tighten. Do not over-tighten. The o-ring and gasket should be slightly compressed. Match the sensor threaded flow-through head connection against the mating receptacle in the sensor flow-through head.

2.1.3 Step 3 –Electrical Installation



DANGER: Electrical connections on the rear of the Model 5100E Oxygen analyzer may have hazardous voltages present once power has been applied to the unit. High voltages may remain present for a short time even after power has been disconnected from the analyzer. Take care in observing standard electrical practices when making electrical connections to the Model 5100E Oxygen analyzer.

DANGER: The Model 5100E analyzer is not rated intrinsically safe or explosion proof. Be certain that no flammable gases are present in the area where the Model 5100E analyzer will be installed.

CAUTION: The Model 5100E housing is not rated waterproof. Do not mount the analyzer or the sensor in an area where it may contact water or other liquid elements.

WARNING: Be certain that all power is OFF to the analyzer and associated wiring (cables) before attempting installation. **DO NOT WORK WITH LIVE WIRES!** Do not leave any exposed wire at the terminal blocks. Before applying power, ensure terminal blocks are fully inserted into the mating connector at the analyzer.

WARNING: The Model 5100E is not equipped with a circuit breaker. A disconnecting switch or a circuit breaker must be installed in series with the mains power to the analyzer.

System Installation and Startup

A label depicting the terminal block arrangement is affixed to the top of the chassis for easy reference during installation and maintenance (VAC configuration shown below). The terminal blocks feature screwed terminals. The terminal blocks are also removable for ease of wiring or removal of the analyzer module.

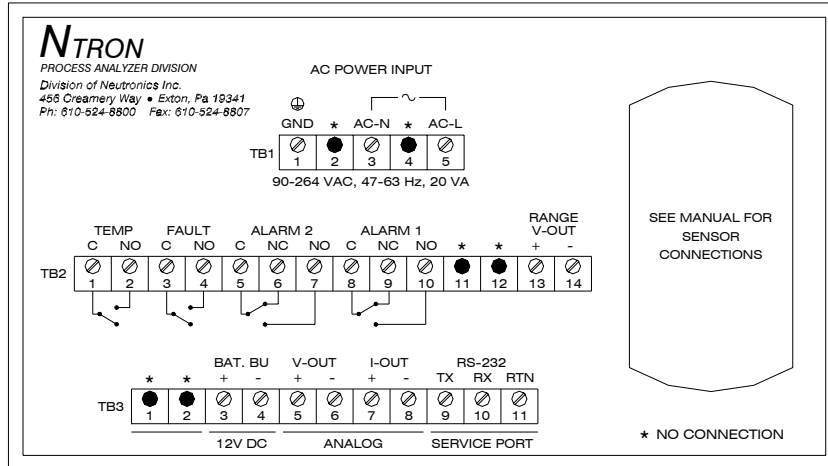

AC Unit Label

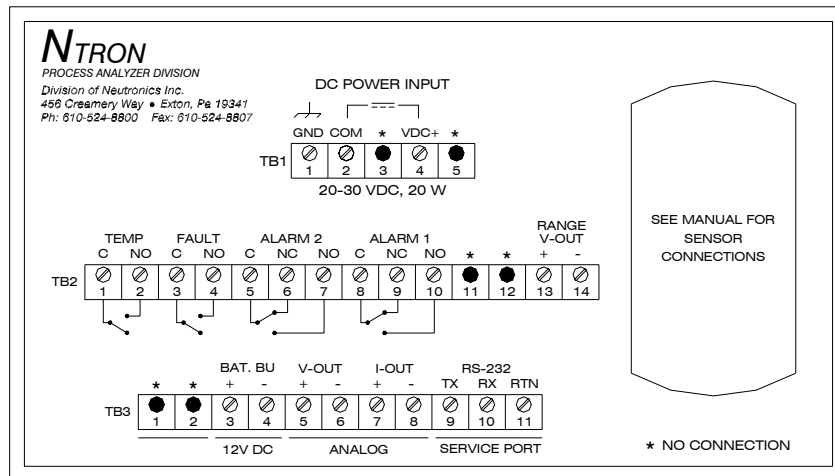

DC Unit Label

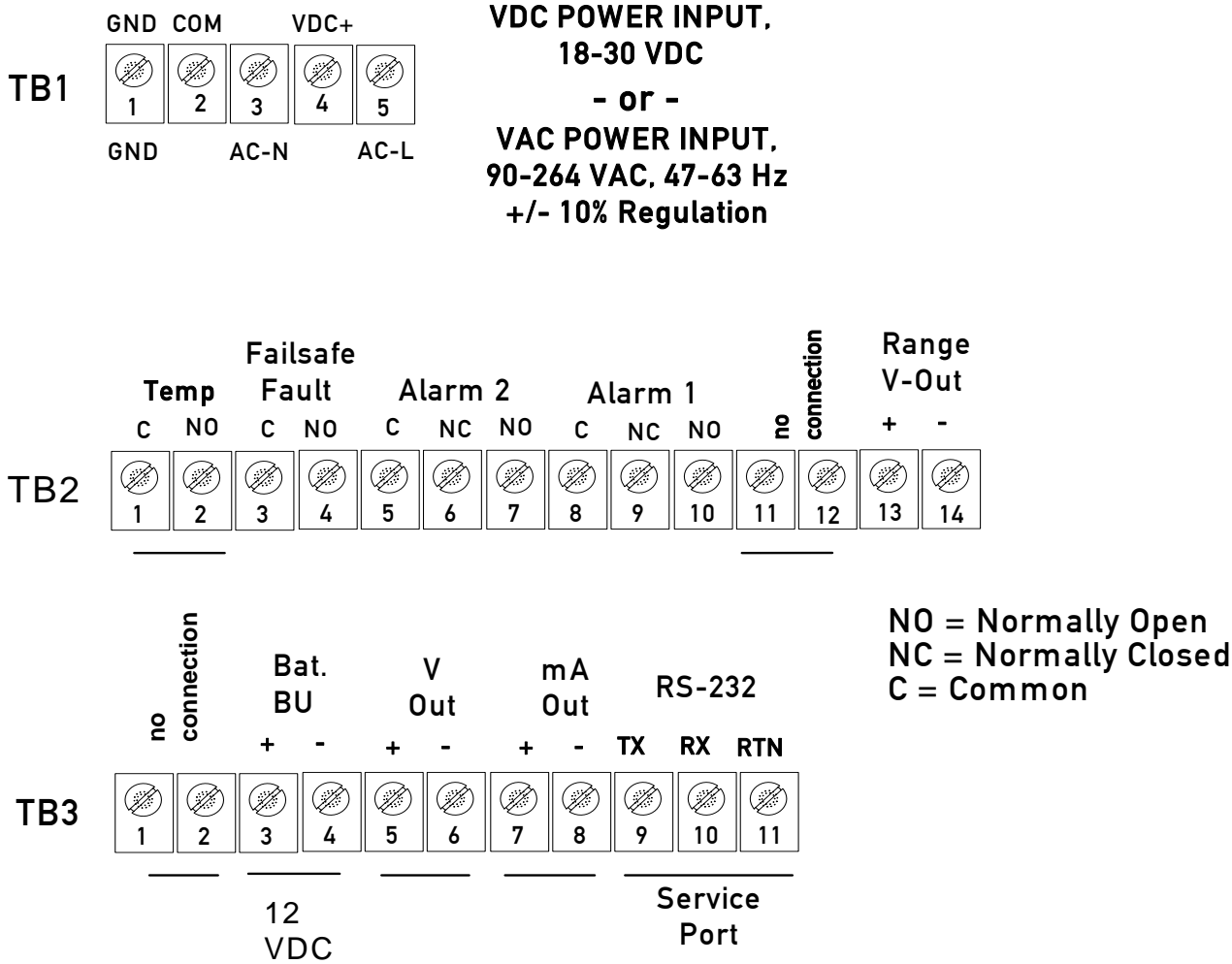

Figure 11 – Analyzer chassis electrical connections

System Installation and Startup

2.1.3.1 Alarm-1 Relay Output

Connections from the Alarm-1 relay contacts to the user's process control equipment are made at terminal block TB2 on the rear of the analyzer chassis. The Oxygen Alarm relay contacts are voltage-free Form 1 C relay contacts, SPDT, 5A @ 250 VAC, 5A @ 30 VDC. Be certain to match the terminal pins against the terminal ID label on the top of the analyzer chassis.

2.1.3.2 Alarm-2 Relay Output

Connections from the Alarm-2 relay contacts to the user's process control equipment are made at terminal block TB2 on the rear of the analyzer chassis. The Oxygen Alarm relay contacts are voltage-free Form 1 C relay contacts, SPDT, 5A @ 250 VAC, 5A @ 30 VDC. Be certain to match the terminal pins against the terminal ID label on the top of the analyzer chassis.

2.1.3.3 Fault Relay Output

Connections from the Fault relay contacts to the user's process control equipment are made at terminal block TB2 on the rear of the analyzer chassis. The Fault relay contacts are voltage-free Form 1 B relay contacts, SPST, 5A @ 250 VAC, 5A @ 30 VDC, failsafe open. When the Model 5100E is powered, and there are no faults, the contact is closed. Be certain to match the terminal pins against the terminal ID label on the top of the analyzer chassis.

2.1.3.4 Range ID Output

Connections from the Range ID output to the user's auxiliary equipment are made at terminal block TB2 on the rear of the analyzer chassis. Be certain to match the terminal pins against the terminal ID label on the top of the analyzer chassis.

Use 20-AWG, 2-conductor, stranded-wire, twisted pairs for the connections. It is not necessary to use shielded cable for the Range ID output, with or without electrical barriers. If shielded cable is used, it should be drained to dc ground at the auxiliary equipment.

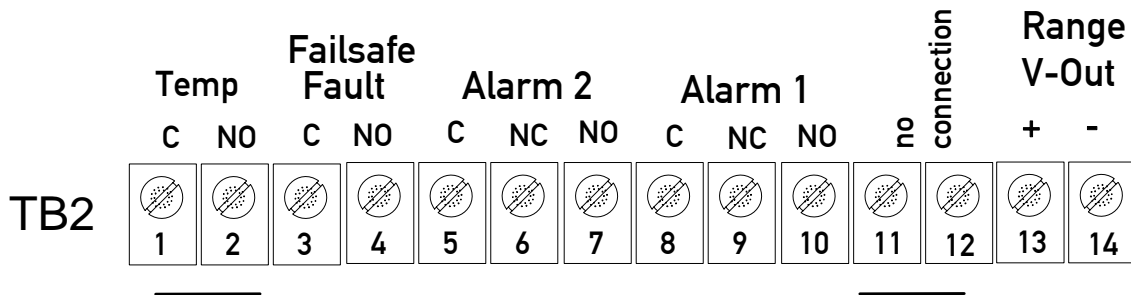

2.1.3.5 Analog Voltage Output

Connections from the Analog Voltage output to the user's auxiliary equipment are made at terminal block TB3 on the rear of the analyzer chassis. Be certain to match the terminal pins against the terminal ID label on the top of the analyzer chassis.

Use 20-AWG, 2-conductor, stranded-wire, twisted pairs for the connections. It is not necessary to use shielded cable for the Analog Voltage output, with or without electrical barriers. If shielded cable is used, it should be drained to dc ground at the auxiliary equipment.

2.1.3.6 Analog Current Output

Connections from the Analog Current output to the user's auxiliary equipment are made at terminal block TB3 on the rear of the analyzer chassis. The Analog current output is a negative ground, non-isolated 0-20mA, or 4-20 mA current loop. 12 VDC Power is supplied by the Model 5100E analyzer. Maximum electrical loading is 250 Ohms. Be certain to match the terminal pins against the terminal ID label on the top of the analyzer chassis.

Use 20-AWG, 2-conductor, stranded-wire, twisted pairs for the connections. It is not necessary to use shielded cable for the Analog Current output, with or without electrical barriers. If shielded cable is used, it should be drained to dc ground at the auxiliary equipment.

2.1.3.7 Battery Backup

12-volt DC Battery Backup terminals are provided at terminal block TB3 on the rear of the analyzer chassis. These terminals may be connected to a fixed 12 VDC power source to act as a back up in case mains power has been lost. The circuit will detect loss of the mains power and the VDC battery backup will maintain power to the analyzer.

Reminder relay contacts are voltage-free. User devices controlled by the Model 5100E relay contacts require additional power backup measures.

Connection to the battery backup is not required for normal operation of the analyzer. Be certain to match the terminal pins against the terminal ID label on the top of the analyzer chassis.

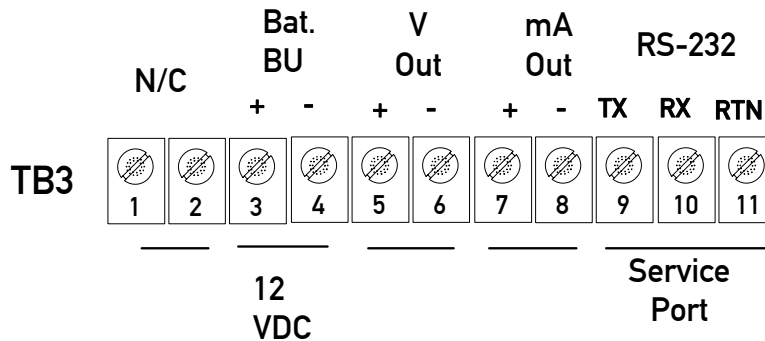

System Installation and Startup

2.1.3.8 RS-232 Service Port

Connections from the Range ID output to the user's auxiliary equipment are made at terminal block TB3 on the rear of the analyzer chassis. Be certain to match the terminal pins against the terminal ID label on the top of the analyzer chassis.

For interfacing with any standard PC computer via serial port, use 20-AWG, 3-conductor, shielded, stranded-wire, jacketed cable, terminated on one end with a female DB9 connector. The shielding should be drained to DC ground at the computer. A ferrite core is provided (for DC units) to minimize interference from the host computer. Install the ferrite core within 6 inches of the analyzer service port. Loop the serial cable around the ferrite core once (the serial cable will pass through the ferrite core twice) (see Figure 12).

SIGNAL DESIGNATION AT ANALYZER	ANALYZER TB2 CONNECTION	SIGNAL DESIGNATION AT COMPUTER	COMPUTER DB9 SERIAL PORT CONNECTION
TX	Pin 9	RX	Pin 2
RX	Pin 10	TX	Pin 3
RTN	Pin 11	RTN	Pin 5

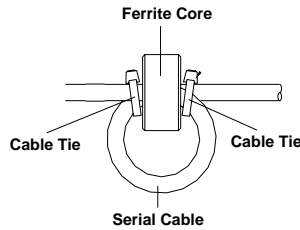
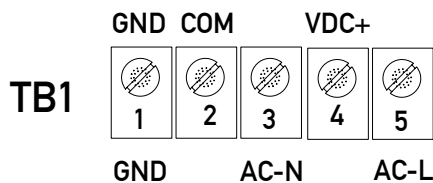

Figure 12 – Ferrite Core

2.1.3.9 Mains Power

Connections for Mains Power input are made at terminal block TB1 on the rear of the analyzer chassis. Be certain to match the terminal pins against the terminal ID label on the top of the analyzer chassis.

For VAC versions, use minimum 16-AWG, 3-conductor, stranded-wire, for the connections. Supply single-phase 110/220 VAC, 50/60Hz to the unit. For VDC versions, use 18-AWG, 3-conductor, stranded-wire, for the connections. Supply 12 or 30 VDC to the unit. All supply voltages are to be regulated at +/- 10%. Refer to Certificate of Analysis (supplied with each analyzer from the factory) for the correct voltage to use with your unit. Refer to Appendix B for detailed mains power specifications. Note: Install a disconnecting device or a circuit breaker between the mains power and terminal block TB1.



**VDC POWER INPUT,
18-30 VDC**

- or -

**VAC POWER INPUT,
90-264 VAC, 47-63 Hz
+/- 10% Regulation**

2.2 Starting up and Commissioning the System

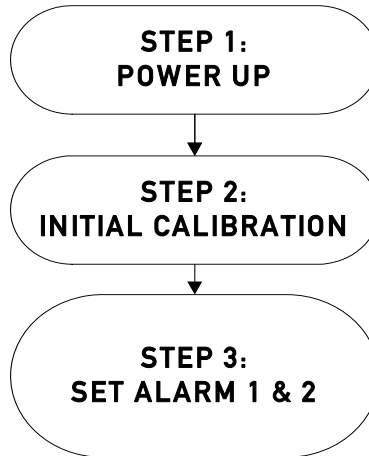

Figure 13 – Start-up outline

The Model 5100E is shipped ready to use, right from the carton. Factory default configuration settings are listed in Appendix C for your information. Those settings will be suitable for most applications. Review the factory default configuration settings before commissioning your system. If you wish to change any of the factory default settings, refer to sections 4.1.1 and 4.1.2.

POWER UP CHECK LIST

Have you:

- Mounted the analyzer and sensor in areas where there are no flammable vapors?
- Mounted the system away from exposure to rain, dripping water, or hose down?
- Correctly installed all of the wiring?
- Connected the sensor interface cable at both the sensor and analyzer?
- Ensured gas tight plumbing at the sensor flow-through head?
- Regulated the sample pressure as instructed in section 2.1.2.2 (Figure 10)?
- Read this manual in its entirety?

2.2.1 STEP 1 – Power Up the unit

When the Model 5100E is powered-up, it will go through a 5-second self-test. The 7-segment alphanumeric display will show “8.8.8.8.”, then XXXX (software build). The Run, Alarm-1, Alarm-2 and Fault LED indicators will go through a display test sequence (Lamp Test). The unit will then begin a 60-second warm-up period for the heated Zirconium Oxide oxygen sensor. The 7-segment alphanumeric display will show alternately XX.X (the timer count-down in seconds), and “nr”.

When the warm-up period is complete, the Model 5100E will check the sensor signal, update the display and status LED’s, and enter into the appropriate system mode according to programmed parameters (refer to the Software Setup Log that is supplied by the factory, for the configuration details of your Model 5100E). Once the analyzer reading has stabilized, the user may apply an instrument air source to the sensor to check the system. Allow the new reading to stabilize. It should take about 30 seconds for the gas to sweep out the sample lines, depending on the length.

System Installation and Startup

2.2.2 STEP 2 – Calibrate the Unit

All units are calibrated at the Neutronics factory before shipping. However, it is recommended that the Model 5100E be calibrated at commissioning, under ambient and process conditions similar to those encountered while in-service. Refer to section 3.2.1 for detailed analyzer calibration instructions.

Helpful hint The Model 5100E is configured-to-order, as specified by the user per the application. If the application has changed, some adjustments in the system configuration may be necessary to optimize the Model 5100E performance for the application. After reviewing the calibration instructions (section 3.2.1), review the Certificate of Analysis supplied with the analyzer and verify that the current settings are suitable for the application. Refer to Appendices E and F for all valid range and output settings available on the Model 5100E. If any changes are necessary, they can be performed via the control panel (section 4.1.1) or the service port (section 4.1.2).

2.2.3 STEP 3 –Set Alarm-1 and Alarm-2

After the unit has been calibrated on known gas sources, set the alarm thresholds according to process control requirements. Refer to Appendix C for factory settings.

2.2.3.1 Set Alarm-1

For process control applications, alarm-1 is used normally as the “primary” oxygen-level alarm, and is set to the highest or lowest level of oxygen allowable in your process, according to the application. Refer to section 3.2.2 for information about changing the alarm-1 level.

2.2.3.2 Set Alarm-2

For process control applications, alarm-2 is used normally as the “secondary”, or “warning” oxygen-level alarm, and is set just below the highest, or just above the lowest level of oxygen allowable in your process, according to the application. Refer to section 3.2.3 for information about changing the alarm-2 level.

The Model 5100E should now be ready for commissioning. Neutronics Inc. offers commissioning, and Factory Acceptance Testing services by our qualified technicians. You may contact the Neutronics factory toll-free at (800) 378-2287 in the continental United States. Elsewhere, call (610) 524-8800 and ask an Ntron Division Service Technician to schedule a service call.

3

CHAPTER 3 – ANALYZER OPERATION

3.1 System Organization

The Model 5100E has two types of operational modes – User-type, and Operating-type. User modes are initiated and controlled by the user, and are used to setup and maintain the analyzer. The User modes are: Calibration, Set/View Alarm-1, Set/View Alarm-2, View Active Faults, and Setup. Operating type modes are controlled automatically by the Model 5100E during normal operation, according to its programming, and its configuration parameters. The Operating modes are: Self-Test & Warm-up, Run, Alarm-1 Active, Alarm-2 Active, and Fault Active.

3.2 USER Modes

Once the analyzer has stabilized, the user can initiate any of the user modes either from the control panel or through the service port. Control panel access of the Calibration, Set/View Alarm-1, Set/View Alarm-2 and View Active Faults modes will be covered in this chapter. System Setup mode and user access via the service port will be covered in section 4.1.

The user modes Calibration, Set/View Alarm-1, Set/View Alarm-2 and View Active Faults are accessed via the control panel, in the aforementioned order by repeatedly pressing and releasing the “MODE” key. When a user mode is accessed via the control panel, the Model 5100E aborts any operating mode that is active, and holds the state of Alarm-1, Alarm-2, and Fault, and Heater OK relay outputs until the user returns the unit to Run mode.

3.2.1 CALIBRATE Mode & Calibration Procedure

Calibration mode allows the oxygen sensor and analyzer to be aligned to gases of known oxygen concentration for accurate on-line readings. Factory calibration has been performed at 0 (less than 100 ppm), and 20.9% or 95.0% depending on your range selection. Refer to the Software Setup Log (that is supplied by the factory) for the configuration details of your Model 5100E.

3.2.1.1 Step-1: Remove the Oxygen Sensor from Online Service

The oxygen sensor requires removal from on-line service to perform calibration. Calibration or other maintenance of the Model 5100E analyzer and sensor should be performed when the measured process is not operating. If the unit has been installed with a Neutronics Inc process sampling system, please refer to the equipment manual for detailed instructions.

Warning Before opening any part of the sampling system to air, make sure that the sampling lines are not pressurized, and are clear of any gas that may create a personnel or environmental hazard.

Analyzer Operation

Disconnect the measured process from the sensor by completely removing the installed 1/8" MNPT fittings from the sensor flow-through head sample inlet port (this step is not necessary if using a fixed gas manifold – section 2.3.1). If it is necessary to exhaust to an alternate path during calibration, completely remove the installed 1/8" MNPT fittings from the sensor flow-through head sample exhaust port. Connect the oxygen sensor to an alternate exhaust location as in section 2.1.2.3.

3.2.1.2 Step-2: Apply zero calibration gas to the Oxygen Sensor (Optional – This calibration has been performed at the factory. The user may perform this calibration for verification using the procedure below

Note: The Model 5100 analyzer must be calibrated to a nitrogen zero gas that is at least 99.999% pure. Failure to do so will affect the accuracy of the analyzer. Any other inert gas may be substituted if the process background gas is a gas other than nitrogen.

Attach a regulated (see Appendix B) calibration gas source to the sample inlet of the sensor flow through head. Note that to maintain accuracy of the analyzer, it is strongly recommended that the calibration gas pressure and flow rate is similar to the process gas pressure and flow rate. Wait for the analyzer display to stabilize (at least 5 minutes).

Warning: Never apply an unregulated gas supply to the oxygen sensor. Failure to do so may cause damage to the oxygen sensor.

3.2.1.3 Step-3: Calibrate the Analyzer (Optional)

After a regulated stream of calibration gas has been applied to the sensor, press and release the "MODE" key once. The 7-segment alphanumeric display will show "CAL", then an oxygen concentration value. Adjust the displayed oxygen concentration value to read "0.00" by pressing the "UP" or "DOWN" arrow key as required. Press and release the "MODE" key four times to return to Run mode.

Note: The calibration data will not be updated if the "UP" or "DOWN" key is not pressed. If the analyzer reading is exactly similar to your calibration gas, press the "UP" key once and then the "DOWN" key once before pressing the "MODE" key four times to ensure that the calibration information is updated.

3.2.1.4 Step-4: Apply span calibration gas to the analyzer

Note: The Model 5100E analyzer has been factory calibrated to either ambient air for 0-25% full scale range version, or 95% for 0-100% full scale range version. Please refer to the certificate of calibration for details on the analyzer's factory span gas. The accuracy of the analyzer may be improved by performing your span calibration with a certified calibration gas at or near your expected process gas concentration.

Warning: Do not use a span calibration gas concentration below 1% or above 95%. Failure to comply will significantly compromise the accuracy of the analyzer.

Warning: All span calibration gases, except for compressed air, must be certified test gases. Failure to comply will significantly compromise the accuracy of the analyzer.

Warning: Use instrument grade and regulated compressed (dew point $<35^{\circ}$, particulates $<3\mu$, condensable hydrocarbons $<1\text{ppm}$) air, only when calibrating to air as span gas. Simply exposing the sample inlet port to air during span calibration will compromise the accuracy of the analyzer.

Warning: Only use binary certified calibration gases to calibrate the analyzer. The background gas must be inert. The background gas must match the process background gas. Failure to comply will significantly compromise the accuracy of the analyzer.

Attach a regulated calibration gas source to the sample inlet of the analyzer. Note that to maintain accuracy of the analyzer, it is strongly recommended that the calibration gas pressure and flow rate is similar to the process gas pressure and flow rate. Wait for the analyzer display to stabilize (at least 5 minutes).

Warning: Never apply an unregulated gas supply to the oxygen sensor. Failure to do so may cause damage to the oxygen sensor.

3.2.1.5 Step 5 Calibrate the analyzer

After a regulated stream of calibration gas has been applied to the sensor, press and release the “MODE” key once. The 7-segment alphanumeric display will show “CAL”, then an oxygen concentration value. Adjust the displayed oxygen concentration value to match the span gas concentration by pressing the “UP” or “DOWN” arrow key as required. Press and release the “MODE” key four times to return to Run mode.

Note: The calibration data will not be updated if the “UP” or “DOWN” key is not pressed. If the analyzer reading is exactly similar to your calibration gas, press the “UP” key once and then the “DOWN” key once before pressing the “MODE” key four times to ensure that the calibration information is updated.

3.2.2 SET/VIEW ALARM-1 Mode

To enter Set Alarm-1 mode from run mode using the keypad; scroll through the user mode menu by pressing momentarily the “MODE” key two (2) times, until the 7-segment alphanumeric display reads “AL1” (set alarm-1 level), and the “RUN” and “ALM1” indicator LED’s flash. The display will show momentarily “AL1” and then the current alarm-1 threshold level (an O_2 concentration). Use the “UP” and “DOWN” keys to adjust the alarm-1 setpoint level. Changed settings are automatically saved when the “MODE” key is pressed to enter the next mode.

Analyzer Operation

3.2.3 SET/VIEW ALARM-2 Mode

To enter Set Alarm-2 mode from run mode using the keypad; scroll through the user mode menu by pressing momentarily the “MODE” key three (3) times, until the 7-segment alphanumeric display reads “AL2” (set alarm-2 level) and the “RUN” and “ALM2” indicator LED’s flash. The display will show momentarily “AL2” and then the current alarm-2 threshold level (an O₂ concentration). Use the “UP” and “DOWN” keys to adjust the alarm-2 setpoint level. Changed settings are automatically saved when the “MODE” key is pressed to enter the next mode.

3.2.4 VIEW ACTIVE FAULTS Mode

To enter View Active Faults mode from run mode using the keypad; scroll through the user mode menu by pressing momentarily the “MODE” key four (4) times until the 7-segment alphanumeric display reads “FL”, and the “RUN” and “FAULT” indicator LED’s flash. The display will show momentarily “FL” and then the highest priority active system fault. Press and release the “UP” or “DOWN” key to scroll through all active system faults. Refer to section 4.3.1 for a complete fault code listing, and troubleshooting guide. To exit, press and release the “MODE” key.

3.2.5 Return to RUN Mode

To exit to run mode from any user mode, using the keypad; scroll through the control panel user mode menu by pressing repeatedly the “MODE” key until the 7-segment alphanumeric display shows “run”. The display will then show an oxygen concentration. The “RUN”, “ALM1”, “ALM2”, and “FAULT” LED’s will flash for 120 seconds to indicate that the analyzer is in a stabilization period. This is to allow time to sweep the sample lines with sample gas before returning the unit to on-line service. During the stabilization period, alarm-1, alarm-2, and fault, relays remain inactive, and held to their last state before the control panel user mode menu was accessed.

3.3 System Modes

The Model 5100E has five System modes – Self-Test & warm-up, Run, Alarm-1 Active, Alarm-2 Active, or Fault Active. Self-Test & Warm-up are fixed routines that are initiated upon each start-up. The remaining system modes, provided no valid manual input is received at the control panel or service port, are initiated automatically by the analyzer according to setup parameters entered by the user in Setup mode, and are compared against monitored inputs and other monitored system hardware in real time.

3.3.1 Self-Test & Warm-up Mode

When the Model 5100E is started up, it enters into Self-Test & Warm-up mode automatically (section 2.2.1). When the analyzer self-test is complete, the unit checks the current sensor signal, updates the 7-segment LED display, status LED’s, and Analog outputs, then enters into the appropriate system mode according to its programmed parameters.

3.3.2 RUN Mode

The Model 5100E initiates Run mode when it is continuously measuring the oxygen concentration of the in-service sample gas, and updating the display and outputs accordingly, and it has not detected any valid user input. A flashing “RUN” indicator LED indicates to the user that the instrument is on-line, and the system is operating properly.

When the measured process oxygen concentration falls outside of programmed alarm parameters, and/or the system experiences a fault condition, the Model 5100E analyzer enters into Alarm-1 Active, Alarm-2 Active, and/or Fault Active mode accordingly. The system does not abort Run mode, and the “RUN” indicator LED stays lit. The appropriate indicator LED will light in addition to the “RUN” indicator LED.

When programmed alarm setpoints and/or fault conditions are cleared, the Model 5100E analyzer aborts Alarm-1 Active, Alarm-2 Active, and/or Fault Active mode accordingly. The system does not abort Run mode, and the “RUN” indicator LED stays lit. Indicator LED’s mapped to aborted modes go out.

When the Model 5100E analyzer detects valid user-input, it enters into one of the user modes accordingly – Calibration, Set/View Alarm-1, Set/View Alarm-2, View Active Faults, or User Setup. The analyzer aborts Run mode and holds the state of Alarm-1, Alarm-2, and Fault. The “RUN” indicator LED goes out, except in Calibrate mode, where it flashes.

When the user manually aborts all user modes by returning the system to Run mode, or no valid user input is detected for 120-seconds, the Model 5100E checks the current sensor signal, updates the 7-segment LED display, status LED’s, and Analog outputs, then enters into the appropriate system mode according to its programmed parameters. Alarm-1, Alarm-2, and Fault relay outputs are released and the “RUN” indicator LED is lit.

3.3.3 ALARM-1 ACTIVE Mode

The Model 5100E initiates Alarm-1 Active mode when it has detected that the measured oxygen concentration has exceed the set threshold value of Alarm-1 (section 3.2.2). The “ALM1” indicator LED will light, The “RUN” indicator LED will remain lit. The Alarm-1 relay will change state according to the analyzer configuration (refer to the Software Setup Log that is supplied from the factory). The Alarm status will be cleared automatically when the measured oxygen concentration is within the set threshold value of Alarm-1. The “ALM1” indicator LED will go out, and the Alarm-1 relay will return to its non-active state according to the analyzer configuration. The Alarm-1 Active mode is held to its last state during manual access to the user mode menu.

3.3.4 ALARM-2 ACTIVE Mode

The Model 5100E initiates Alarm-2 Active mode when it has detected that the measured oxygen concentration has exceed the set threshold value of Alarm-2 (section 3.2.3). The “ALM2” indicator LED will light, The “RUN” indicator LED will remain lit. The Alarm-2 relay will change state according to the analyzer configuration (refer to the Software Setup Log that is supplied from the factory). The Alarm status will be cleared automatically when the measured oxygen concentration is within the set threshold value of Alarm-2. The “ALM2” indicator LED will go out, and the Alarm-2 relay will return to its non-active state according to the analyzer configuration. The Alarm-2 Active mode is held to its last state during manual access to the user mode menu.

3.3.5 FAULT ACTIVE Mode

The fault relay is a failsafe relay. Any type of condition that produces a fault on the analyzer will light the :Fault” LED and open the fault relay. Once the faults have been cleared, the LED will turn off and the contacts on the fault relay will close. The user may view active faults at any time from the control panel (section 3.2.4).

4 CHAPTER 4 – MAINTENANCE AND TROUBLESHOOTING

4.1 System Setup

The Model 5100E is shipped ready to install and operate with complete factory configuration already programmed and tested. The user may however wish to change the system configuration to suit the application of the analyzer. Some setup parameters may be changed by the user via the control panel keypad. All configuration parameters may be changed by the user via the Service Port.

Important: Before changing any of the Model 5100E settings, refer to the Software Setup Log that is supplied from the factory for reference. If the user has any questions before proceeding with changing analyzer settings, please contact the Neutronics Inc. Ntron Division Service Department for assistance.

4.1.1 System Setup via Control panel Keypad

The control panel user setup menu may be accessed from the Model 5100E control panel by pressing and holding the “MODE” key for at least 10-seconds until the 7-segment alphanumeric display shows “---” to indicate that the analyzer has accessed setup mode. Release the “MODE” key to activate setup mode. Once in setup mode, the user can access adjustable parameters sequentially by continuing to press and release the “MODE” key to scroll through the setup menu.

When you reach the mode that you wish to change, use the “UP” and “DOWN” keys to adjust the displayed setting. The modes are numerically identified by the number on the left side of the display. The current mode setting is identified by the number on the right side of the display. The new settings are automatically saved when the user advances to the next mode by pressing and releasing the “MODE” key. The user may exit the Setup menu at any time by pressing simultaneously the “UP” and “DOWN” keys (Appendix D, Control panel Hot-Key functions).

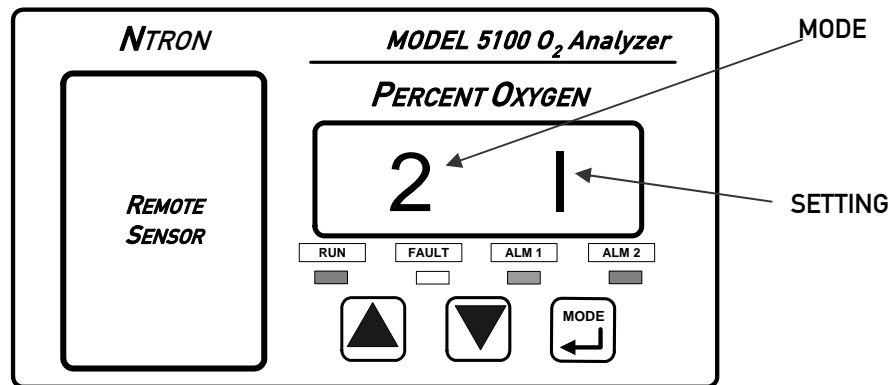

4.1.1.1 User Setup A: Display Range Select

This parameter allows the user to map the display and electrical output range scale of the Model 5100E to suit the application (Appendix E – Range / Output Chart).

Valid Settings: 1 (fixed range 0-1 %) • 2 (fixed range 0-10 %) • 3 (fixed range 0-25 %) • 4 (fixed range 0-50 %) • 5 (fixed range 0-100 %) • 8 (low auto-range 0-25%) • 9 (high auto-range 10-100%) • 10 (full auto-range 0-100%)

Maintenance and Troubleshooting

4.1.1.2 User Setup 1: Alarm-1 Relays Ascending/Descending Action

This parameter allows the user to set the Alarm-1 relay action to *ascending* (the relay is set to its active state when the oxygen level is above the Alarm-1 level set point) or to *descending* (the relay is set to its active state when the oxygen level is below the Alarm-1 level set point).

Valid Settings: 1 (Descending) • 0 (Ascending)

4.1.1.3 User Setup 2: Alarm-2 Relays Ascending/Descending Action

This parameter allows the user to set the Alarm-2 relay action to *ascending* (the relay is set to its active state when the oxygen level is above the Alarm-2 level set point) or to *descending* (the relay is set to its active state when the oxygen level is below the Alarm-2 level set point).

Valid Settings: 1 (Descending) • 0 (Ascending)

4.1.1.4 User Setup 3: Analog Voltage Output Setting

This parameter allows the user to set the Analog Output Voltage full scale to 1, 5, or 10 volts. *Note that the software settings must match the RA and RB jumper settings on the Main CPU PCB* (section 4.1.3).

Valid Settings: 0 (0-5 VDC) • 1 (0-10 VDC), 2 (0-1 VDC)

4.1.1.5 User Setup 4: Serial Output Format

This parameter allows the user to set the RS-232 communications timed output format.

Valid Settings: 0 (Output on Request) • 1 (Human Readable) • 2 (Machine Code) • 3 (Machine Code with Checksum) • 4 (Tab Delimited)

4.1.1.6 User Setup 5: Analog 4-20mA Output Calibration

User Setup mode 5 allows the user to adjust the high and low span values of the Analog 4-20mA output from the Model 5100. To access user setup mode 5, use the “MODE” key to scroll through the user setup mode menu as normal, until user setup mode 5 is reached. The LED display will show “4.00” to indicate that the unit is ready for the low span output adjustment.

Adjust the low span output: Connect a multi-meter to TB3, Pin 7 (+), and TB3, Pin 8 (-). Set the multimeter to read milli-Amperes. Use the “UP” and “DOWN” keys to adjust the analyzer LED display to match the reading on the multi-meter.

Adjust the high span output: Press and release the “MODE” key once. The analyzer LED display will show “20.00” to indicate that the unit is ready for the high span output adjustment. With the multi-meter still connected to TB3, Pin 7 (+), and TB3, Pin 8 (-), use the “UP” and “DOWN” keys to adjust the analyzer display to match the reading on the multi-meter.

4.1.1.7 User Setup 7: Set Assume Low-End Calibration Range Code

DO NOT CHANGE THIS SETTING

4.1.1.8 User Setup F: Alarm-1 and Alarm-2 Relays Failsafe/Non Failsafe Action

This parameter allows the user to set the Alarm-1 and Alarm-2 relays to either *failsafe* action (relay coils not powered in active alarm state) or *non-failsafe* (relay coils powered in active alarm state).

Valid Settings: 0 (Non-Failsafe) • 1 (Failsafe)

4.1.1.9 User Setup B: RS-232 Baud Rate

This parameter allows the user to set the RS-232 communications baud rate.

Valid Settings: 1 (300BPS) • 2 (1200BPS) • 3 (2400BPS) • 4(4800BPS) • 5 (9600BPS)
6 (19200BPS) • 7 (38400BPS)

4.1.1.10 User Setup 8: Factory Setup Restore.

This parameter allows the user to return the Model 5100E to its initial factory-commissioned settings. Always perform a gas calibration after restoring factory settings.

Valid Settings: 88. A setting of 88 will activate the Factory Setup restore.

4.1.2 System Setup via Service Port

The Model 5100E analyzer features a Service Port, which is accessible for programming the system, monitoring the analyzer output, and determining active fault codes for troubleshooting. The Service Port has been designed for communication with a PC based computer or other device capable of receiving and transmitting ASCII data packets over a standard RS-232 serial interface.

Access to the Serial Service Port may be made through a terminal emulator program such as **HyperTerminal**, available in Microsoft Windows 95 or later:

4.1.2.1 RS-232 Service Port Interfacing with HyperTerminal in Microsoft Windows 95 or later

Turn off your PC computer, and remove power from the Model 5100E. Complete the instructions for wiring and connecting the Model 5100E to a PC computer (section 2.1.3.10). Apply power to the Model 5100E, and start up the PC computer.

On your PC computer, open HyperTerminal: Navigate from the Windows desktop – Select **Start** → **Programs** → **Accessories** → **Communications** → **HyperTerminal**

In HyperTerminal, create and configure a new connection – follow the prompts:

PROMPT	YOU ENTER
CONNECTION NAME	5100E
CONNECT TO	COM1, or other available COM port

In HyperTerminal, select the correct COM port properties, to interface properly with the Model 5100E:

PROPERTIES	YOU ENTER
BITS PER SECOND	9600
DATA BITS	8
PARITY	None
STOP BITS	1
FLOW CONTROL	None
TERMINAL EMULATION	VT 100 *

* Terminal Emulation may not be selectable with all operating systems.

Select “Apply” and “OK” as prompted. The Hyper Terminal program will immediately begin communicating with the Model 5100E, and the Model 5100E will commence sending data via ASCII code dump to the PC. The information from the analyzer will be sent in ASCII strings, at 1-second intervals. Data will be sent in the factory default “Human Readable” format unless another format is requested by the user.

Maintenance and Troubleshooting

4.1.2.2 Troubleshooting Your HyperTerminal Interface

If serial communications with the Model 5100E fails, isolate the problem by performing the following tests:

Disconnect the RS-232 cable from the Model 5100E by removing the terminal block connector from TB3. Insert a jumper between pins 9 & 10 on the terminal block connector. Enter a few letters from the PC keyboard. The PC monitor should display the corresponding alpha-characters as they are typed. If the letters do not display on the monitor screen, there is a problem with the RS-232 cable, the PC serial COM port, or the HyperTerminal setup.

If the typed letters DO show on the monitor screen and serial communications with the Model 5100E still has not been established, then PC COM port pins 2 & 3 (5100E pins 9 & 10) may be reversed. Verify the cable wiring (section 2.1.3.8). If no transmitted data from the Model 5100E is seen on the monitor screen, call the Neutronics Inc. Service Department for further assistance.

4.1.2.3 Organization of RS-232 Serial Data

There are three levels of access through the service port that can be used for interfacing with the Model 5100E:

Standard Access: ASCII dump to a PC, printer, or DAQ, and provides basic operator access.

Advanced Level-1 Access: Allows user setup and configuration, such as alarms, and data format.

Advanced Level-2 Access: Allows access to vital control areas via password (call factory with analyzer serial number).

4.1.2.4 Standard Level Access

Standard Level Access is the default level of access to the Model 5100E available to the user via a host computer or printer over a standard RS-232 serial interface. In Standard Level access, the user can make inquiries about oxygen concentration, sensor signal level, and other parameters for system servicing, and troubleshooting.

When communications are established between the Model 5100E and a host computer, 2-way communication begins automatically in Standard Level access. Data is sent out the analyzer RS-232 Service Port to the host terminal once-per-second, in the factory-default Human Readable format (section 4.1.2.4.2). There are no commands necessary to begin viewing information transmitted by the Model 5100E in Standard Level access.

To request and view specific information via the RS-232 interface, type the desired command key selected from the Standard Access level command chart below (It is not necessary to press return).

Helpful Hint: For viewing convenience, before requesting specific information from the Model 5100E, disable automatic 1-second updates from the Model 5100E and allow access of information by-request-only (section 4.1.2.4.1), by typing "SSERFMT=0", followed by the Return key. To return to automatic 1-second updates of data from the analyzer in Human Readable format (section 4.1.2.4.2), type "SSERFMT=1", followed by the Return key.

The STANDARD ACCESS level commands

TYPED COMMAND	DESCRIPTION OF QUERIED FUNCTION
A	Short software version
C	Analyzer Model number
E	Sensor output in Percent Oxygen
G	Sensor output in Volts
H	Active Fault codes (32 bit codes in hex)
I	Active Fault code descriptions
V	Long software version
@	Unit Serial Number

There are several data formats of the ASCII data dump available. They may be changed from the user specified format (refer to the Software Setup Log that is supplied from the factory) to any format listed below:

TYPED COMMAND	DESCRIPTION OF QUERIED FUNCTION
SSERFMT=0	Disables RS-232 continuous OUTPUT ON REQUEST
SSERFMT=1	Enables RS-232 output in HUMAN READABLE format
SSERFMT=2	Enables RS-232 output in MACHINE format w/o Checksum
SSERFMT=3	Enables RS-232 output in MACHINE format w/Checksum
SSERFMT=4	Enables RS-232 output in TAB DELIMITED (Excel®) format
SCALIBRATE=.XXXXXX	The user can send a calibration value in decimal format where 100 % Oxygen = 1. The number format entered must be 6-decimal places.

4.1.2.4.1 Disable RS 232 continuous OUTPUT ON REQUEST – SSERFMT=0

While this setting is active, the user must request information by pressing the desired key according to the STANDARD ACCESS level commands chart.

4.1.2.4.2 Human Readable Data Format – SSERFMT=1

Human Readable data is presented in dynamic columns (columns appear only when data is present). It is intended for most users, to aid in setup and maintenance of the unit. Column headings from left to right: **Mode • O₂ Concentration • Alarm-1 status • Alarm-1 status • list of Fault codes active.**

4.1.2.4.3 Machine Data Format with NO Checksum

Machine format with NO checksum can be selected via the analyzer control panel, or through the RS-232 interface in Standard Access level. Machine format with NO checksum data is streamed in packets defined by start/stop transmit bits. The order of data in each packet is as follows: **Start Transmit • O₂ Concentration • Fault codes active • List of Fault Codes • Alarm-1 status • Alarm-1 status • End Transmit.** For detailed information on data formats, please contact the Neutronics Service Department.

Maintenance and Troubleshooting

4.1.2.4.4 Machine Code Format WITH Checksum

Machine code with checksum can be selected via the analyzer control panel, or through the RS-232 interface in Standard Access level. Machine format with checksum data is streamed in packets defined by start/stop transmit bits. The order of data in each packet is as follows: **Start Transmit • O₂ Concentration • Fault codes active • List of Fault Codes • Alarm-1 status • Alarm-2 status • Checksum • End Transmit.** For detailed information on data formats, please contact the Neutronics Service Department.

4.1.2.4.5 Tab delimited Data Format

Tab delimited format can be selected via the analyzer control panel, or through the RS-232 interface in Standard Access level. Tab delimited data is presented in static columns (the same number of columns is always transmitted in a complete data message). Column headings from left to right: **Time since last re-boot^{tab} • Mode^{tab} • O₂ Concentration^{tab} • Alarm-1 status^{tab} • Alarm-2 status^{tab} • list of Fault codes active^{tab}.** For detailed information on data formats, please contact the Neutronics Service Department.

4.1.2.5 Advanced Level 1 Access

Advanced Level-1 access is the computer-interfaced user Setup mode. Access to Advanced Level-1 can be accomplished on a PC by typing “setup” when viewing the Human Readable ASCII output. The User Setup menu will be displayed on the PC screen allowing access for changing the system setup.

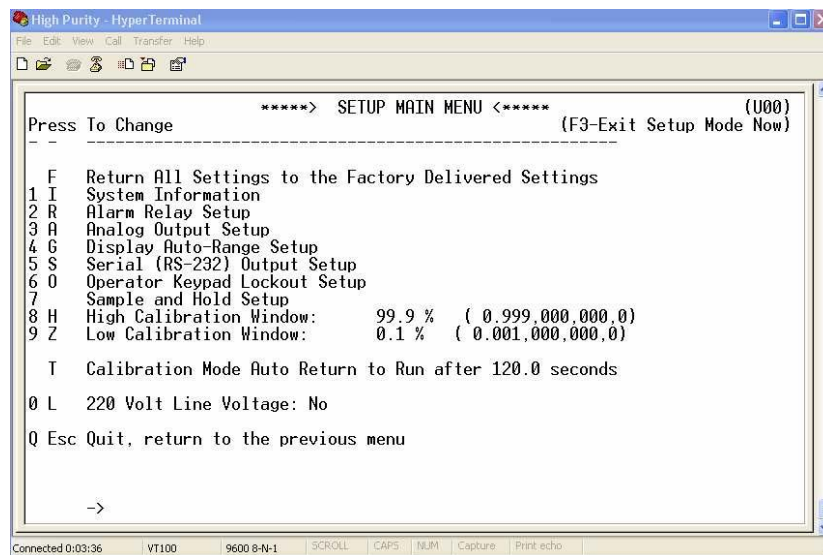

```
High Purity - HyperTerminal
File Edit View Call Transfer Help
*****> SETUP MAIN MENU <***** (U00)
Press To Change ----- (F9-Exit Setup Mode Now)
-----
F Return All Settings to the Factory Delivered Settings
1 I System Information
2 R Alarm Relay Setup
3 A Analog Output Setup
4 G Display Auto-Range Setup
5 S Serial (RS-232) Output Setup
6 O Operator Keypad Lockout Setup
7 Sample and Hold Setup
8 H High Calibration Window: 99.9 % ( 0.999,000,000,0)
9 Z Low Calibration Window: 0.1 % ( 0.001,000,000,0)
T Calibration Mode Auto Return to Run after 120.0 seconds
0 L 220 Volt Line Voltage: No
Q Esc Quit, return to the previous menu

->
```

Figure 14 – Level-1 Access (SETUP) Mode Menu

4.1.2.6 Advanced Level-2 Access

Advanced Level-2 access is available to the user via a PC by use of a password. This level of access allows the manipulation of all code settings. Contact the Neutronics Inc. Service Department for support before attempting to use Advanced Level-2 access.

4.1.2.7 (U00) SETTING UP THE MODEL 5100E – The RS-232 User Setup Menu

The RS-232 User Setup menu U00 (see Figure 14) is the “Home” screen in Advanced Level-1 access (section 4.1.2.5), and provides access to all the parameters that may need to be adjusted by the user. The interactive menu is initiated by typing “setup” and pressing the “Enter” key on the RS-232 terminal; as in entering Advanced Level-1 access. To navigate backwards, use the <Esc> or “Q” key on the RS-232 terminal.

4.1.2.8 Return all Settings to Factory Delivered Settings

In case of severe corruption of calibration and setting information, this setting will allow the user to restore the Model 5100E analyzer to its “out-of-box” setting. The user may type “Y” at the prompt to initiate a restore, or “N” and the prompt to bypass a restore. This setting is accessed from the Setup Main Menu by typing “F” on the RS-232 Terminal. To navigate backwards, use the <Esc> or “Q” key on the RS-232 terminal.

4.1.2.9 System Information Display

The System Information Display **U10** (see Figure 15) is a list of all the current settings for the 5100E analyzer. It is accessed from the Setup Main Menu by typing “1” or “I” on the RS-232 Terminal.

```

High Purity - HyperTerminal
File Edit View Call Transfer Help
(F3-Exit Setup Mode Now)
-System Configuration- SN 132219 Device 5 ->Model 5100 (%02)
Ver 1.7.1.46 (Mo 20 Sep 04 15:15:26) build 1771 CS 0x2345 7710 No
EEWriteCnt 26 FacOK Yes 220VLine No OprAccess: Setp-Yes Range-Yes Cal-Yes
-Display Range Jumpers: Hardware 0 Software 10
Auto Return To Run 120.0 sec

Low Cal Win: ' 0.1 % ( 0.001,000,000.0)' High Cal Win: ' 99.9 % (
0.999,000,000.0)' (F3-Exit Setup Mode Now)
-Serial: Baud '5 ->9600' Fmt '1 ->Human Readable' Spacing 1.0 sec Dbg No 0A
-1 Style: No
-RELAYS FailSafe Yes Minimum On Time 0.0 sec Stby After Cal 120.0 sec
Fault Active during Warm Up No
ALM1 Descending No Setpoint 5.0 % ( 0.050,000,000.0)
ALM2 Descending No Setpoint 10.0 % ( 0.100,000,000.0)
-ANALOG OUTPUTS VOut Jumpers '2->Jumper RA-OUT RB-IN 0.0 .. 1.0 V'
Fixed User Output Ranges No 4to20mA Yes AOLock Yes User Ranges:
V( 0.0 % ( 0.000,000,000.0) to 100.0 % ( 1.000,000,000.0))
I( 0.0 % ( 0.000,000,000.0) to 100.0 % ( 1.000,000,000.0))
AOCals 5V(0.430,4098.3) 10V(0.066,3808.0) 1V(0.586,4038.8) I(66.214,3827.1)
Cell Type '4 ->NGK MOL007 Cell'
Gain '6 ->B64 +/-39.063 mVolts' Sensor Disconnect No CalErr Window 100%
Temp '0->No Temperature Compensation' TCal: V 0.200,000,0 T 25.0
-> Press any key to continue...
Volt,Con,Temp 1( 0.000,005,4, 0.0 % ( 0.000,000,000.0), 25.0)
2( 0.002,423,5, 20.9 % ( 0.209,319,700.0), 25.0)
3( 0.000,000,0, 0.0 % ( 0.000,000,000.0), 25.0)
-Sensor Zero Offset 0.000,000,0
-Fuzzy Stabilizer Acc 0.0 % ( 0.000,100,000.0) LPFT 10.0 RespT 5.0
-Sample&Hold No AutoExit No HoldT 0s Lvl 0% Damp 0%
-> Press any key to continue...

Connected 0:05:36 | VT100 | 9600 8-N-1 | SCROLL | CAPS | NUM | Capture | Print echo

```

Figure 15 – System Information Display

Maintenance and Troubleshooting

4.1.2.10 (U20) Alarm Relay Setup Menu

The RS-232 Alarm/Relay Setup menu **U20** (see **Figure 16**) provides access to all of the settings related to the Alarms, controls, and relays on the Model 5100E analyzer. It is accessed from the Setup Main Menu by typing “2” or “R” on the RS-232 Terminal. To navigate backwards, use the <Esc> or “Q” key on the RS-232 terminal.

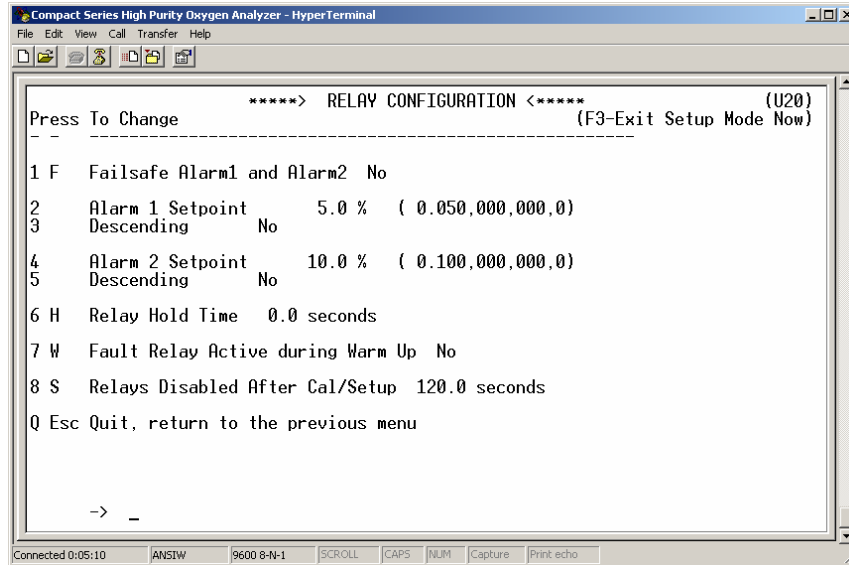

Figure 16 – Relay Configuration Menu

4.1.2.10.1 Alarm-1 and Alarm-2 Relays Failsafe

This parameter allows the user to set the Alarm-1 and Alarm-2 relays to either *failsafe* or *non-failsafe* action. *Failsafe* action is defined as; relay coils are not powered (contacts are in *normal* position) in active alarm state. *Non-Failsafe* action is defined as; relay coils are powered (contacts are in *non-normal* position) in active alarm state. The Alarm-1 and Alarm-2 Relays Failsafe setting may be set to “YES” or “NO”. This setting is accessed from the Alarm and Relay Setup Menu by typing “1” or “F” on the RS-232 terminal. Refer to the Software Setup Log (that is supplied by the factory) for the alarm relay configuration of your Model 5100E

4.1.2.10.2 Alarm-1 Level Setting (setpoint)

This setting sets the threshold level for Alarm-1. Depending on whether or not it is set to ascending or descending, Alarm-1 becomes active when the oxygen concentration is above or below this threshold level. The Alarm-1 setpoint may be set anywhere from 0.0 % to 100.0%. This setting is accessed from the Alarm Relay Setup Menu by typing “2” on the RS-232 terminal. Refer to the Software Setup Log (that is supplied by the factory) for the alarm setpoint configuration of your Model 5100E

4.1.2.10.3 Alarm-1 Descending

This setting configures Alarm-1 to either ascending or descending action. Ascending is defined as Alarm-1 active when the oxygen concentration is above the Alarm-1 setpoint level. Descending is defined as; Alarm-1 active when the oxygen concentration is below the alarm-1 setpoint level. The descending setting may be set to “YES” or “NO”. This setting is accessed from the Alarm and Relay Setup Menu by typing “3” on the RS-232 terminal. Refer to the Software Setup Log (that is supplied by the factory) for the alarm configuration of your Model 5100E

4.1.2.10.4 Alarm-2 Level Setting (setpoint)

This setting sets the threshold level for Alarm-2. Depending on whether or not it is set to ascending or descending, Alarm-2 becomes active when the oxygen concentration is above or below this threshold level. The Alarm-2 setpoint may be set anywhere from 0.0 % to 100.0 %. This setting is accessed from the Alarm Relay Setup Menu by typing “4” on the RS-232 terminal. . Refer to the Software Setup Log (that is supplied by the factory) for the alarm setpoint configuration of your Model 5100E

4.1.2.10.5 Alarm-2 Descending

This setting configures Alarm-2 to either ascending or descending action. Ascending is defined as Alarm-2 active when the oxygen concentration is above the Alarm-2 setpoint level. Descending is defined as; Alarm-2 active when the oxygen concentration is below the alarm-2 setpoint level. The descending setting may be set to “YES” or “NO”. This setting is accessed from the Alarm and Relay Setup Menu by typing “5” on the RS-232 terminal. . Refer to the Software Setup Log (that is supplied by the factory) for the alarm configuration of your Model 5100E

4.1.2.10.6 Relay Hold Time

This setting determines the minimum time that Alarm-1 and Alarm-2 relays will hold their active state once the Alarm-1 and Alarm-2 setpoint levels have been exceeded, regardless of the actual Oxygen concentration after Alarm-1 and Alarm-2 have been activated. The Hold Time level may be set anywhere from 0 to 300 seconds. This setting is accessed from the Alarm Relay Setup Menu by typing “6” or “H” on the RS-232 terminal. . Refer to the Software Setup Log (that is supplied by the factory) for the alarm relay configuration of your Model 5100E

4.1.2.10.7 Fault Relay Active during Warm-up

This setting determines the active status of the Fault relay during the Model 5100E warm-up routine (section 4.3.1.2). The activate setting may be set to “YES” or “NO”. This setting is accessed from the Alarm Relay Setup Menu by typing “7” or “W” on the RS-232 terminal. . Refer to the Software Setup Log (that is supplied by the factory) for the fault realy configuration of your Model 5100E

4.1.2.10.8 Relays Disabled after CAL/Setup

This setting determines the time that relays will be held in their last state before returning to Run mode from the control panel or service port user menus. The relays disabled time may be set anywhere from 0 to 14,400 seconds. This setting is accessed from the Alarm Relay Setup Menu by typing “8” or “S” on the RS-232 terminal. . Refer to the Software Setup Log (that is supplied by the factory) for the relay configuration of your Model 5100E

Maintenance and Troubleshooting

4.1.2.11 (U30) Analog Output Setup Menu

The RS-232 Analog Output Setup menu **U30** (see **Figure 17**) provides access to all of the settings related to the Analog Voltage Output (TB3-Pin 5, TB3-Pin 6) and Analog Current Output (TB3-Pin 7, TB3-Pin 8). It is accessed from the Setup Main Menu by typing “3” or “A” on the RS-232 terminal. To navigate backwards, use the <Esc> or “Q” key on the RS-232 terminal.

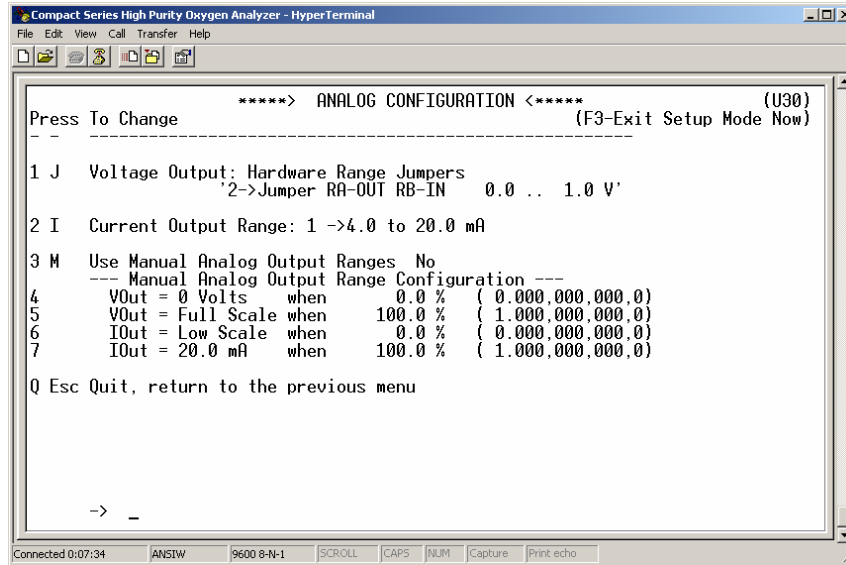

Figure 17 – Analog Output Configuration Menu

4.1.2.11.1 Analog Voltage Output Range

This menu sets the Analog Voltage Output full-scale value. It may be set to 0 (0-5 VDC minimum to full scale), 1 (0-10 VDC minimum to full scale) or 2 (0-1 VDC minimum to full scale). This setting must match the RA and RB hardware jumper settings on the bottom of the main CPU PCB (section 4.1.3). This menu is accessed from the Analog Output Setup menu by typing “1” or “J” on the RS-232 terminal. Refer to the Software Setup Log (that is supplied by the factory) for the configuration details of your Model 5100E

4.1.2.11.2 Analog Current Output Range

This menu sets the Analog Current Output range. It may be set to 0 (0-20mA minimum to full scale), or 1 (4-20mA minimum to full scale). This menu is accessed from the Analog Output Setup menu by typing “2” or “I” on the RS-232 terminal. Refer to the Software Setup Log (that is supplied by the factory) for the configuration details of your Model 5100E

4.1.2.11.3 Use Manual Analog Output Ranges

This menu is used to enable manual override of Analog output mapping to display range, and to force minimum and maximum Analog outputs to absolute Oxygen measurement values. This menu is accessed from the Analog Output Setup menu by typing “3” or “M” on the RS-232 terminal. Contact factory before changing these settings.

4.1.2.11.4 Force minimum Voltage Output to O₂ Concentration

This menu sets the Oxygen concentration at which the Analog Voltage output is at zero. This setting is entered in percent oxygen increments, and can be anywhere from 0.0 % to 100.0 %. This menu is accessed from the Analog Output Setup menu by typing “4” on the RS-232 terminal. Contact factory before changing these settings.

4.1.2.11.5 Force Maximum Voltage to O₂ Concentration

This menu sets the Oxygen concentration at which the Analog Voltage output is at maximum range (section 4.1.2.11.1). This setting is entered in percent oxygen increments and can be anywhere from 0.0 % to 100.0 %. This menu is accessed from the Analog Output Setup menu by typing “5” on the RS-232 terminal. . Contact factory before changing these settings.

Maintenance and Troubleshooting

4.1.2.11.6 Force minimum Current Output to O₂ Concentration

This menu sets the Oxygen concentration at which the Analog Current output is at minimum range (section 4.1.2.11.2). This setting is entered in percent oxygen increments and can be anywhere from 0.0 % to 100.0 %. This menu is accessed from the Analog Output Setup menu by typing “6” on the RS-232 terminal. . Contact factory before changing these settings.

4.1.2.11.7 Force Maximum Current Output to O₂ Concentration

This menu sets the Oxygen concentration at which the Analog Current output is at maximum range (section 4.1.2.11.2). This setting is entered in percent oxygen increments and can be anywhere from 0.0 % to 100.0 %. This menu is accessed from the Analog Output Setup menu by typing “7” on the RS-232 terminal. . Contact factory before changing these settings.

4.1.2.12 Display/Auto-Range Setup

The RS-232 Display/Auto-Range Setup menu **U14** (see Figure 18) provides access for the user to map the display and Analog output range scale(s) of the Model 5100E to suit the application (Appendix E – Range / Analog output Chart). The Analog Output Range may be set to 1 (fixed range 0-1 %) • 2 (fixed range 0-10 %) • 3 (fixed range 0-25 %) • 4 (fixed range 0-50 %) • 5 (fixed range 0-100 %) • 8 (low auto-range) • 9 (high auto-range) • 10 (full auto-range). This menu is accessed from the Setup Main Menu by typing “4” or “G” on the RS-232 terminal. To navigate backwards, use the <Esc> or “Q” key on the RS-232 terminal. . Refer to the Software Setup Log (that is supplied by the factory) for the configuration details of your Model 5100E

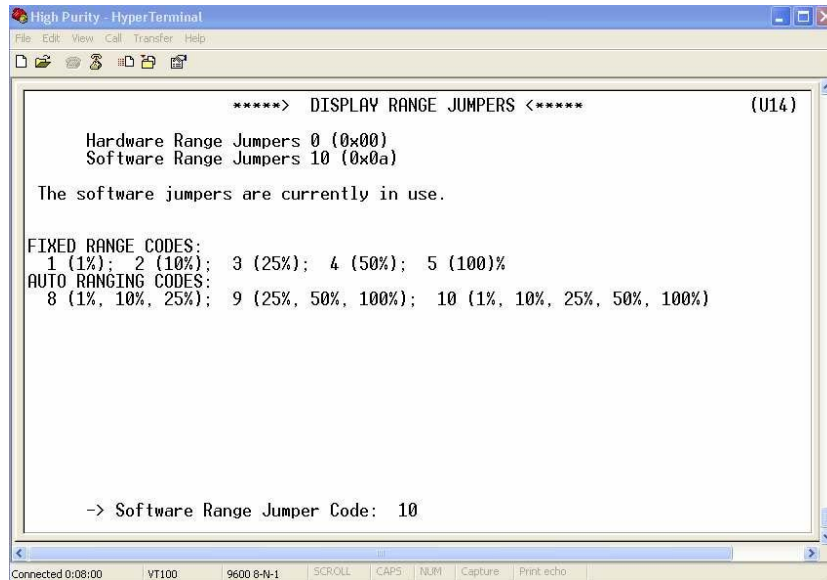

Figure 18 – Display/Auto Range Setup Menu

4.1.2.13 (U50) RS-232 Serial Setup Menu

This menu (see Figure 19) provides access to set the RS-232 serial communications options. It is accessed from the Setup Main Menu by typing “5” or “S” on the RS-232 terminal. To navigate backwards, use the <Esc> or “Q” key on the RS-232 terminal.

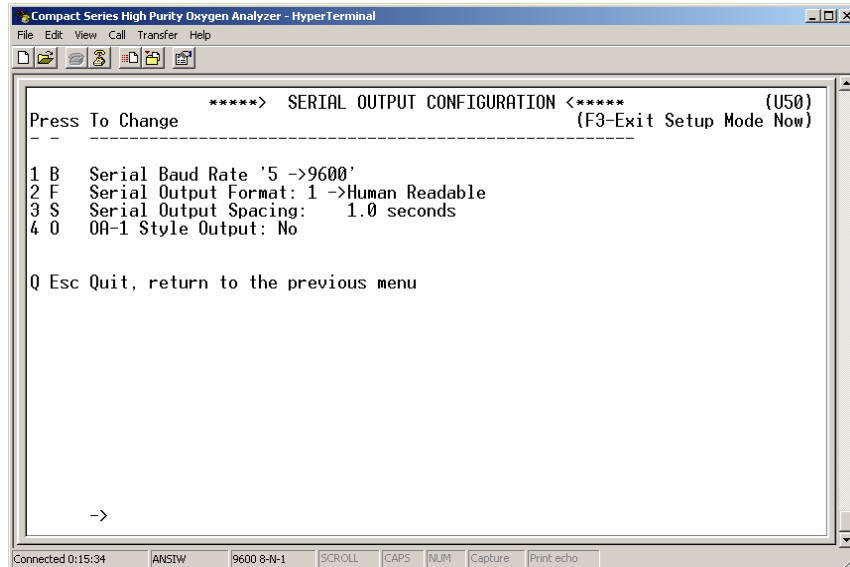

Figure 19 – Serial Output Configuration Menu

4.1.2.13.1 Baud Rate

This menu sets the RS-232 baud rate. The baud rate can be set to 1 (300BPS), 2 (1200BPS), 3 (2400BPS), 4 (4800BPS), 5 (9600BPS), 6 (19200BPS) or 7 (38400BPS). This menu is accessed from the RS-232 Serial Setup menu by typing “1” or “B” on the RS-232 terminal. Refer to the Software Setup Log (that is supplied by the factory) for the configuration details of your Model 5100E

Maintenance and Troubleshooting

4.1.2.13.2 Automatic Serial Output Format

This menu sets the format of the automatic timed RS-232 serial output (section 4.1.2.4). The timed serial output format may be set to 0 (Output on Request), 1 (Human Readable), 2 (Machine Code), 3 (Machine Code with Checksum), 4 (Tab delimited) 5 (OA1 style; not used). This menu is accessed from the RS-232 Serial Setup menu by typing “2” or “F” on the RS-232 terminal. . Refer to the Software Setup Log (that is supplied by the factory) for the configuration details of your Model 5100E

4.1.2.13.3 Serial Output Spacing

This menu sets the rate at which the RS-232 sends complete ASCII data packets to the Service Port. The send rate can be set anywhere from 1 to 86,400 seconds (24-hours). This menu is accessed from the RS-232 Serial Setup menu by typing “3” or “S” on the RS-232 terminal. . Refer to the Software Setup Log (that is supplied by the factory) for the configuration details of your Model 5100E

4.1.2.13.4 OA1 Style Output – NOT USED, DO NOT CHANGE

4.1.2.14 Alarm Setpoint Lockout

If the Alarm Setpoint Lockout is enabled, the user may not change, but only view the Alarm-1 and Alarm-2 level settings. The Alarm Lockout setting can be found in the Operator Keypad Lockout Menu (U60 sub menu) which can be accessed from the Setup Main Menu by typing “6” or “O” on the RS-232 terminal. To navigate backwards, use the <Esc> or “Q” key on the RS-232 terminal.

4.1.2.15 Gas Calibration Lockout

If the Gas Calibration Lockout is enabled, the user may not change, but only view the Gas Calibration value. The Gas Calibration Lockout setting can be found in the Operator Keypad Lockout Menu (U60 sub Menu) which can be accessed from the Setup Main Menu by typing “7” or “O” on the RS-232 terminal. To navigate backwards, use the <Esc> or “Q” key on the RS-232 terminal.

4.1.2.15.1 User Menu Lockout

If the Front Menu Lockout is enabled the user may not manually initiate any User mode from the control panel. The User Menu Lockout setting can be found in the Operator Keypad Lockout Menu (U60 sub Menu) which can be accessed from the Control panel Locks menu by typing “8” or “O” on the RS-232 terminal. To navigate backwards, use the <Esc> or “Q” key on the RS-232 terminal.

4.1.2.16 Assume Low-End Calibration Range

WARNING: The Assume Low-End Calibration Range (Zero Calibration Range in the setup menu) is set to 0 % to 5 % Oxygen at the factory, and it should not be adjusted by the user. If the user changes the Assume Low-End Calibration Range setting, the Model 5100E will not operate properly.

4.1.2.16.1 Calibration Mode Auto Return to RUN

This setting determines the minimum time that the Model 5100E allows after exiting from control panel or service port user menus, before returning the unit to on-line status. The calibration mode auto return setting is accessed from the Control panel Locks menu by typing “T” on the RS-232 terminal. To navigate backwards, use the <Esc> or “Q” key on the RS-232 terminal.

4.1.2.17 220 Volt Line Voltage – NOT USED, DO NOT CHANGE

4.1.3 Change factory settings via Hardware Jumpers

4.1.3.1 Analog Voltage Output

The Analog voltage output must be configured using the hardware settings (see Figure 19). In addition, the software settings must match the jumper settings. Software changes are made via the Control panel User Setup menu (section 4.1.1), or the Service Port RS-232 User Setup menu (section 4.1.2.7).

4.1.3.1.1 Remove the unit from service

Make certain that all interfacing to the Model 5100E is disabled at the user device. Make sure that interrupting outputs, from the unit will not interfere with normal process monitoring or control. Disconnect power from the Model 5100E unit. Disconnect the removable terminal blocks from the rear of the Model 5100E chassis. Follow all lock-out/tag-out procedures.

4.1.3.1.2 Change jumper settings

Turn the Model 5100E upside down to access the jumpers through the port provided. Identify the appropriate jumper position. Use an insulated jumper-puller to remove and replace jumpers (Figure 20).

4.1.3.1.3 Return to service

Replace cables, and terminal blocks. Reapply power. Change Analog Voltage Output setting from control panel or service port to match new hardware settings. Perform a calibration check. Check function of changes to ensure the new settings are recognized by the Model 5100E.

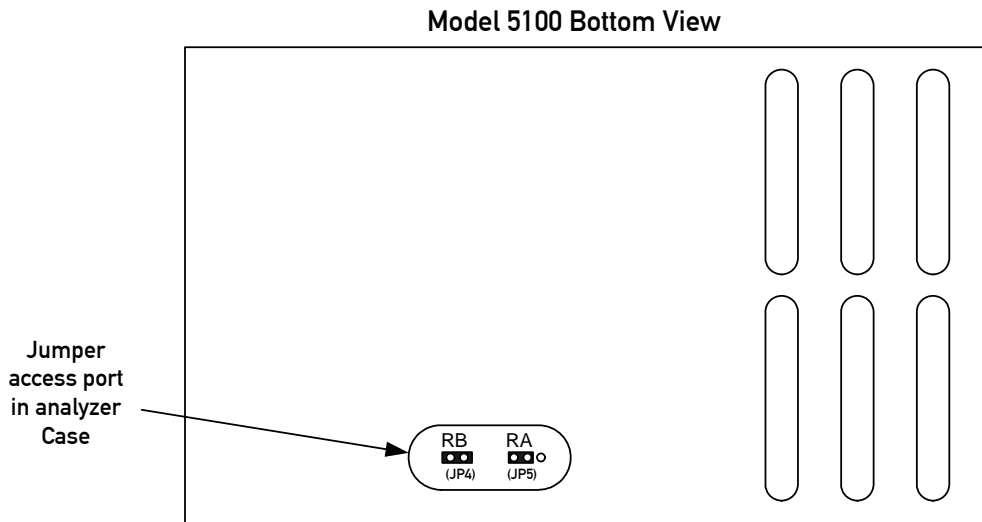

Figure 20 – Range select jumpers

JP4 / JP5 JUMPERS (1=SHORTED; 0=OPEN)		SELECT VOLTAGE OUTPUT RANGE
RA	RB	
1	0	$V_{out} = 0-1$ VDC
0	0	$V_{out} = 0-5$ VDC
0	1	$V_{out} = 0-10$ VDC

Figure 21 – Range select jumper settings

Maintenance and Troubleshooting

4.2 Routine Periodic Maintenance

Maintenance for the Model 5100E Oxygen analyzer is very simple. Apart from the normal maintenance for any instrument, such as cleaning the chassis, wiping the display, and replacing the sensor, the Model 5100E does not require any major periodic servicing. Calibration of the sensor on a known gas source should be performed during the customer's regular maintenance schedule. The chart below should serve as a general guide for maintenance personnel.

TASK	RECOMMENDED FREQUENCY		
	AT COMMISSIONING	EVERY YEAR	AS REQUIRED
Calibrate Sensor	√		√
Clean the analyzer chassis and display panel with soft cloth. Make sure the ventilation ports are clear.		√	√
Configure alarms	√		√
Replace the oxygen sensor			√ *Sensor life expectancy 2 years (under normal use) Warranty – One Year

Actual sensor life may vary according to measurement conditions. Contact factory for additional sensor life evaluations.

Figure 22 –Maintenance schedule

4.3 Troubleshooting

4.3.1 Fault Codes

When trouble occurs during normal operation of the Model 5100E, the user has several tools available to aid in isolating the cause(s) of given symptoms. As a starting point, the user may use the control panel to enter into “View Active Faults” mode (section 3.2.4). The user may also view active faults and other useful information via the Service Port (section 4.1.2). In addition, there are four system Hot-Keys available to perform special functions, and to gather important information quickly and easily (Appendix-D). Descriptions of faults are given below, with indication of common causes. Refer to the appropriate sections of this manual for more details as needed.

4.3.1.1 Fault Code 1 – Sensor is warming up

The “Sensor warming up” fault indicates that the oxygen sensor is being heated to its operating temperature. Fault code 1 activates for about 60 seconds after the analyzer is powered up. The purpose of the alarm is to provide a control output to indicate that the sensor has not yet reached its operating temperature, and the Model 5100E is not yet ready for in-service oxygen measurement. After the warm-up period is complete the fault indication will be de-activated.

4.3.1.2 Fault Code 2 – Relays are in Standby mode

Fault 2 indicates that the analyzer relay outputs, which are the alarm 1 relay, alarm 2 relay, fault relay, and temperature OK relay, are in standby mode. The relays are “locked” at the last valid condition before the relay standby mode is initiated. The situations that initiate relay standby modes are:

- The unit is powered up or power cycled (Note that the relays will be in the inactive mode).
- The unit is warming up.
- The unit is being calibrated.
- The Alarm 1 and/or Alarm 2 setpoints are being changed.
- The active Fault modes are being viewed from the front panel.

After a certain period of time the fault 2 will be de-activated. The factory default setting for the Standby Mode period is 120 seconds (appendix C). The relay Standby Mode timer may be programmed in the user mode (section 4.1.2.10.6).

4.3.1.3 Fault Code 3 – Device is in Setup mode

Fault 3 activates when a user has accessed the User Setup Menu either via the Front Panel Display or the RS-232 interface. Fault 3 will be de-activated when the user exits the User Setup Menu.

4.3.1.4 Fault Code 5 – Analog Output range overflow

Fault 5 is activated when the analog outputs (4-20mA and 0-1/0-5/0-10VDC) cannot represent the measured analyzer reading because the oxygen concentration is higher than the set display range (section 4.1.2.11.1). For example, if the display range is set to represent 0-25%, and the current oxygen concentration measured is 30%, Fault 5 will be activated. Fault 5 will not be activated when the oxygen concentration measurement is below the manual analog output range.

Maintenance and Troubleshooting

4.3.1.5 Fault Code 6 – Analog Output range underflow

Fault 6 is activated when the analog outputs (4-20mA and 0-1/0-5/0-10VDC) cannot represent the measured analyzer reading because the oxygen concentration is lower than the set display range (section 4.1.2.11.1). Note that this can only occur if the lower end of the display range is set to be at a concentration above 0%. For example, if the manual analog output range is set to represent 5-25%, and the current oxygen concentration measured is 2%, Fault 6 will be activated. Fault 6 will not be activated or will be de-activated when the oxygen concentration measurement is above the manual analog output range.

4.3.1.6 Fault Code 8 – A concentration reading is not yet available

Fault 8 indicates that the Analog to Digital converter has not sent a new concentration measurement to the microprocessor. Fault 8 is activated when the analyzer is turned on, and de-activated when the first Analog to Digital converter reading is made available to the microprocessor.

4.3.1.7 Fault Code 11 – Non-native display range

Fault 11 is activated when the analyzer measures an oxygen concentration that is either higher or lower than the display range (section 4.1.2.12). For example, if the Display Range is set to 0-25% Fixed and the analyzer measures 30% oxygen, Fault 11 will activate. Fault 11 will be de-activated when the oxygen concentration measured by the analyzer returns to the selected display range.

4.3.1.8 Fault Code 15 – Bad user calibration

Fault 15 is activated when the data obtained from either the zero or span gas calibration is corrupt, and cannot be used by the analyzer to calculate the current oxygen concentration. Some situations that may cause bad user calibrations are:

- The gas calibration was done on a dead or damaged sensor.

The oxygen concentration that was entered during the calibration procedure does not match the

5

CHAPTER 5 – APPENDICES

5.1 Appendix A – Spare Parts List

PART NUMBER	DESCRIPTION
5-06-4900-08-0	Operations Manual
C1-11-1220-03-0	VAC Fuses for Power Supply Board (for Vac units only). – 1A, 250 VAC, Slo-Blo
C1-17-0052-00-0	Replacement terminal block – TB1
C1-17-0142-00-0	Replacement terminal block – TB2
C1-17-0112-00-0	Replacement terminal block – TB3

5.2 Appendix B - Specifications

OXYGEN SENSOR	External Compact Zirconium Oxide										
DISPLAY	<p>0.75" 7-segment LED digital display, 4 characters Displays oxygen from 0 to 100 percent.</p> <p>Resolution:</p> <table> <tr> <td>0.00–0.99 %</td> <td>X.XX</td> </tr> <tr> <td>1.00–9.99 %</td> <td>X.XX</td> </tr> <tr> <td>10.0–99.9 %</td> <td>XX.X</td> </tr> <tr> <td>100.0 %</td> <td>XXX.X</td> </tr> </table> <p>Color -Coded LED's for system status:</p> <p>RUN: Green FAULT: Yellow ALARM-1: Red ALARM-2: Red</p>	0.00–0.99 %	X.XX	1.00–9.99 %	X.XX	10.0–99.9 %	XX.X	100.0 %	XXX.X		
0.00–0.99 %	X.XX										
1.00–9.99 %	X.XX										
10.0–99.9 %	XX.X										
100.0 %	XXX.X										
SIGNAL INTERFACE	<p>Serial Service Port: Bi-directional RS-232</p> <p>Analog Voltage Output: 0–1, 0–5, or 0–10 VDC</p> <p>Analog Current Output: Non-isolated 4 – 20 mA, 12 VDC, negative ground, powered by analyzer, maximum electrical load 250 Ohms</p> <p>Range ID Voltage:</p> <table> <tr> <td>0 %–1 %</td> <td>5.63 VDC ± 0.1VDC</td> </tr> <tr> <td>0 %–10 %</td> <td>6.25 VDC ± 0.1VDC</td> </tr> <tr> <td>0 %–25 %</td> <td>6.88 VDC ± 0.1VDC</td> </tr> <tr> <td>0 %–50 %</td> <td>7.50 VDC ± 0.1VDC</td> </tr> <tr> <td>0 %–100 %</td> <td>8.13 VDC ± 0.1VDC</td> </tr> </table>	0 %–1 %	5.63 VDC ± 0.1VDC	0 %–10 %	6.25 VDC ± 0.1VDC	0 %–25 %	6.88 VDC ± 0.1VDC	0 %–50 %	7.50 VDC ± 0.1VDC	0 %–100 %	8.13 VDC ± 0.1VDC
0 %–1 %	5.63 VDC ± 0.1VDC										
0 %–10 %	6.25 VDC ± 0.1VDC										
0 %–25 %	6.88 VDC ± 0.1VDC										
0 %–50 %	7.50 VDC ± 0.1VDC										
0 %–100 %	8.13 VDC ± 0.1VDC										
RELAY OUTPUTS	<p>Alarm-1: Field Adjustable Form C (SPDT) Voltage-free, 5A @ 250 VAC, 5A @ 30 VDC. Configurable to fail-safe/non fail-safe and ascending/descending action</p> <p>Alarm-2: Field Adjustable Form C (SPDT) Voltage-free, 5A @ 250 VAC, 5A @ 30 VDC. Configurable to fail-safe/non fail-safe and ascending/descending action</p> <p>Fault: Non-adjustable Form B (SPST) Voltage-free, 5A @ 250 VAC, 5A @ 30 VDC, Fail Safe action, non-configurable.</p>										

The manufacturer reserves the right to amend these specifications as necessary.

RANGE	0–1 % • 0–10 % • 0–25 % • 0–50 % • 0–100 % • Low Auto (0–25 %) • High Auto (10–100 %) • Full Auto (0–100 %)
MEASUREMENT RANGE	0-25%, 0-100%**
ACCURACY OF MEASUREMENT RANGE	± .5% of measurement range
LDL	<u>.05% @ 0-25% measurement range, .1% @ 0-100% measurement range</u>
RESPONSE TIME	T ₉₀ < 15 seconds
WARM UP TIME	60-seconds for sensor warm-up, 35 minutes for temperature equilibrium of the entire analyzer.
HUMIDITY	0-95 % non-condensing
OPERATING TEMPERATURE	Analyzer: 32-122° F (0–50° C) Sensor: 32-122° F (0–50° C)
STORAGE TEMPERATURE	Analyzer: 23-149° F (-5–65° C) Sensor: 23-149° F (-5–65° C)
SAMPLE PRESSURE	15" Hg vacuum–7 PSIG (0.5–1.5 Bar)
SAMPLE FLOW	0.5–1.5 LPM (1 LPM nominal) (1-3 cubic feet per hour)
POWER	VAC Unit: 90 – 264 VAC, 47 – 63 Hz, Single Phase, 13 Watts VDC Unit: 11 – 18 VDC, 13 Watts 20 – 30 VDC, 13 Watts Mains power is to be regulated to +/- 10%
MECHANICAL	Faceplate: Height 3.75" x Width 7.00" • NEMA 4 • IP66 Panel Cut-out: Height 2.91" x Width 6.20" Electronic Compartment: Height 2.81" x Width 5.98" x 3.60" Depth • NEMA 1 • IP20
WEIGHT	3 Lbs (1.4 kg)
WARRANTY	12-months from date of shipment

**Measurement of oxygen >95% affects sensor life significantly, e.g. measuring 100% oxygen will potentially reduce sensor life to less than 6 months. The solid state electrolyte depletes with high oxygen concentrations.

The manufacturer reserves the right to amend these specifications as necessary.

Appendices

5.3 APPENDIX C – ANALYZER FACTORY CONFIGURATION SETTINGS

Alarm and Relay Setup Information

Alarm-1/Alarm-2 Relays Failsafe/Non-Failsafe	NON-FAILSAFE
Alarm-1/Alarm-2 Relay Ascending/Descending	ASCENDING
Alarm-1 Trigger Level	5 %
Alarm-2 Trigger Level	10 %

Display Range

0–1 % Fixed	
0–10 % Fixed	
0–25 % Fixed	
0–50 % Fixed	
0–100 % Fixed	
Low Auto Ranging	
High Auto Ranging	
Full Auto Ranging	X

Rs-232 Baud Rate

300 BPS	
1200 BPS	
2400 BPS	
4800 BPS	
9600 BPS	X
19200 BPS	
38400 BPS	

Rs-232 Timed Output Format

Output on Request Only	
Human Readable Format	X
Machine Code	
Machine Code With Checksum	
Tab Delimited (Spreadsheet)	

Supply Voltage

90 – 264 VAC, 47 – 63 Hz	X
11 – 18 VDC	
20 – 30 VDC	

Analog Voltage Output

0–1 VDC	X
0–5 VDC	
0–10DC	

Analog Current Output

0-20mA	
4-20mA	X

Assume Low-End Calibration Range

1	Single Point	
7	1 %–5 %	X
8	1 %–50 %	
9	18 %–24 %	

Relay Disable after cal/Setup

120 seconds	X
-------------	---

RS-232 Dump Rate

1-second	X
----------	---

5.4 APPENDIX D – Control Panel Hot-Key Functions

For convenience in operating and troubleshooting, the Model 5100E has four Control panel Hot-Key functions that can be performed quickly via the control panel without entering the normal Control panel, or Service Port user menus.

KEYS PRESSED	DESCRIPTION OF FUNCTION
UP + DOWN	Return to “RUN” mode from any User mode
UP + DOWN (hold both keys for 10 seconds *)	Run Lamp Test
DOWN then MODE (hold both keys for 10 seconds *)	Show Sensor Voltage
UP then MODE (hold both keys for 10 seconds *)	Re-start Model 5100E

* Hold all keys indicated until the 7-segment alphanumeric display shows “---“ then release the pressed keys. To return to normal operation, press and release the same keys again.

5.5 APPENDIX E – Range / Output Chart

DISPLAY RANGE NAME	MEASURED RANGE	DISPLAY	ANALOG RANGE	RANGE ID VOLTAGE OUTPUT
FULL AUTO RANGE	0.00 % – .99 %	X.XX	0–1 %	5.63 VDC
	1.00 % – 9.99 %	X.XX	0–10 %	6.25 VDC
	10.0 % – 24.9 %	XX.X	0–25 %	6.88 VDC
	25.0 % – 49.0 %	XX.X	0–50 %	7.50 VDC
	50.0 % – 99.9 %	XX.X	0–100 %	8.13 VDC
	100.0 %	XXX.X		
LOW AUTO RANGE	0.00 % – .99 %	X.XX	0–1 %	5.63 VDC
	1.00 % – 9.99 %	X.XX	0–10 %	6.25 VDC
	10.0 % – 24.9 %	XX.X	0–25 %	6.88 VDC
H IGH AUTO RANGE	10.0 % – 24.9 %	XX.X	0–25 %	6.88 VDC
	25.0 % – 49.0 %	XX.X	0–50 %	7.50 VDC
	50.0 % – 100.0 %	XXX.X	0–100 %	8.13 VDC
FIXED RANGE 0–1 %	0.00 % – .99 %	X.XX	0–1 %	5.63 VDC
FIXED RANGE 0–10 %	0.00 % – 9.99 %	X.XX	0–10 %	6.25 VDC
FIXED RANGE 0–25 %	0.0 % – 9.99 %	X.XX	0–25 %	6.88 VDC
	10.0 % – 24.9 %	XX.X		
FIXED RANGE 0–50 %	0.0 % – 9.99 %	X.XX	0–50 %	7.50 VDC
	10.0 % – 49.9 %	XX.X		
FIXED RANGE 0–100 %	0.0 % – 99.9 %	XX.X	0–100 %	8.13 VDC
	100.0 %	XXX.X		

5.6 APPENDIX F – MSDS Material Safety Data Sheet

1. Product Identification

Oxygen sensor solid state type, Model ZR-500E, furnished by Neutronics Inc. • 456 Creamery Way • Exton, PA USA, 19341 • Telephone: 610-524-8800.

2. Hazardous Ingredients of Solution

None

3. Health Hazard

None

4. Physical and Chemical Data

Yttrium stabilized Zirconia element with platinum electrodes and heater element. No information available. Contact Neutronics Inc for more information if needed.

5. Unusual Fire and Explosion Hazards

None

6. Health Hazard Data

No hazards are encountered during normal operation. Do not touch heated cell. Allow unit to cool down before servicing.

7. Emergency and First-Aid Procedures

Skin Contact with hot sensor: Immediately flush skin with plenty of cold water for 15 minutes.

8. Handling

Protective measures during cell replacement:

Do not remove sensor from analyzer while the instrument is powered or while the sensor is still hot.

Note: The above data is based on MSDS provided by the manufacturers of components and by tests conducted by Neutronics. Neutronics believes that this information to be accurate and reliable. This information is supplied as reference only. Neutronics disclaims any liability for damage or injury which results from the use of the data and nothing contained therein shall constitute a guarantee, warranty, or merchantability or representation by Neutronics with respect to the data, the product described, or their use for any specific purpose, even if that purpose is known to Neutronics.

5.7 APPENDIX G – Warranty

Neutronics warrants to the original purchaser, that the Model 5100E Oxygen analyzer is free from defects in material and workmanship for a period of one (1) year from the date of shipment from Neutronics or from one of Neutronics' authorized dealers. Our liability will be limited to the repair or replacement, at our factory, of parts found to be defective within the warranty period, as determined by Neutronics. The parts will be repaired or replaced free of charge if shipped prepaid to the factory in the original shipping carton. This warranty is void if the product has been subject to misuse or abuse, including but not limited to: exposure to water, humidity, temperature, shock or pressure outside of the listed specifications, or has not been operated or installed in accordance with operating and maintenance instructions, for repairs which were not performed by Neutronics or by one of its authorized dealers, or if the identifying markings on the product label have been altered or removed.

The seller assumes no liability for consequential damages of any kind, and the buyer, by acceptance through purchase of this product, will assume all liability for the consequences of its use or misuse by the buyer, his employees, or others.

Neutronics reserves the right to use any materials in the manufacture, repair or service of the products and to modify the design as deemed suitable, in so far as these materials or modifications maintain the stated warranty.

It is the sole responsibility of the buyer / user to determine if this product is suitable for the intended application.

THESE WARRANTIES ARE EXCLUSIVE AND IN LIEU OF ALL OTHER WARRANTIES, EXPRESSED, OR IMPLIED INCLUDING WARRANTY OF MERCHANTABILITY, FITNESS FOR A PARTICULAR PURPOSE.

Intended Use for the Model 5100E

The Model 5100E Oxygen analyzer was designed to provide the trained operator with useful information relating to the concentration of Oxygen. This information may be used in process control or to minimize possible hazardous conditions, which may be present in various processes. Before implementation, the user must fully understand the operation and limitations of this instrument as well as the application for its use. The responsibility for the proper application, operation, installation, and maintenance of the Model 5100E Oxygen analyzer is the sole obligation of the trained operator. The purchaser is required to ensure operators are properly trained in the use of this unit as well as in the possible hazards associated with its use or with the intended application. The purchaser must ensure that all of the proper warnings, labels, instruction manuals, lock outs, redundant components, hazard analysis, and system validation have been completed and provided to the trained operator before implementation of the Model 5100E instrument.